

Enabling Seamless Ethernet to the Field with 10BASE-T1L Connectivity

Maurice O'Brien, Strategic Marketing Manager
and Volker Goller, System Applications Engineer

10BASE-T1L is a new Ethernet physical layer standard (IEEE 802.3cg-2019) that was approved within IEEE on November 7, 2019. It will dramatically change the process automation industry by significantly improving plant operational efficiency through seamless Ethernet connectivity to field-level devices (sensors and actuators). 10BASE-T1L solves the challenges that, to-date, have limited the use of Ethernet to the field in process automation. These challenges include power, bandwidth, cabling, distance, data islands, and intrinsically safe Zone 0 (hazardous areas) applications. By solving these challenges for both brownfield upgrades and new greenfield installations, 10BASE-T1L will enable new insights that were previously unavailable, such as combining process variables, secondary parameters, asset health feedback, and seamlessly communicating them to the control layer and to the cloud. These new insights will awaken new possibilities for data analysis, operational insights, and productivity improvements through a converged Ethernet network from the field to the cloud (see Figure 1).

been a significant challenge with existing Industrial Ethernet physical layer technologies being limited to 100 m. With distances of up to 1 km required in process automation applications combined with the need for very low power and robust field devices suitable for use in Zone 0 (intrinsically safe) applications, a new approach to realize Ethernet physical layer technology for process automation was required. 10BASE-T1L is this new approach.

10BASE-T1L core capability is a full duplex, dc balanced, point-to-point communication scheme with PAM 3 modulation at a 7.5 MBd symbol rate with 4B3T coding. It supports two amplitude modes: 2.4 V peak-to-peak up to 1000 m cable and 1.0 V peak-to-peak at a reduced distance. The 1.0 V peak-to-peak amplitude mode means that this new physical layer technology can also be used in the environment of explosion-proof (Ex-proof) systems and meet the strict maximum energy restrictions. It enables long transmission distance on 2-wire technology with both power and data on a single twisted pair cable and it belongs to the family of single-pair Ethernet (SPE) media.

10BASE-T1L enables significantly higher power delivery to field devices; up to 500 mW in Zone 0 (intrinsically safe) applications. This is compared to approximately 36 mW with 4 mA to 20 mA devices. In nonintrinsically safe applications, up to 60 W of power is possible depending on the cable used. With significantly more power available at the edge of the network, new field devices with enhanced features and functions can be enabled because the power limitations of 4 mA to 20 mA and field bus no longer apply. For example, higher performance measurement and enhanced edge processing of data is now possible with the additional power. This will unlock valuable insights about process variables that will now be made accessible via a web server running on the field-level devices (field assets), and which will ultimately drive improvements and optimizations in process flows and asset management.

To exploit the rich dataset containing these valuable new insights, a higher bandwidth communications link is required to deliver the dataset from the field devices across the process installation, to plant-level infrastructure or up to the cloud for processing. 10BASE-T1L removes the needs for complex, power hungry gateways, and enables a converged Ethernet network across the information technology (IT) and operating technology (OT) networks. This converged network delivers a simplified installation, easy device replacement, faster network commissioning and configuration. This results in faster software updates with simplified root cause analysis and maintenance of field-level devices.

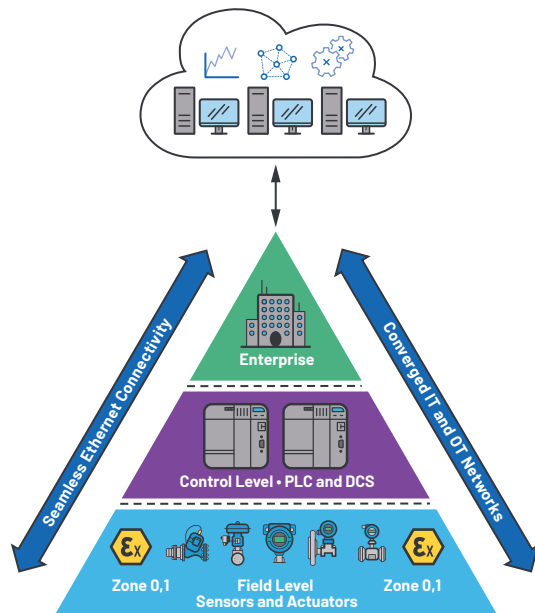

Figure 1. Seamless Ethernet connectivity to process automation field sensors and actuators.

To replace 4 mA to 20 mA or field bus communications (Foundation Fieldbus or PROFIBUS® PA) with Ethernet in process automation applications, both power and data need to be provided to the sensors or actuators over a shielded single twisted pair cable. Single twisted pair cabling has the advantage of being lower cost, smaller size, and easier to install when compared to more complex cabling. The distance between field-level devices in process automation applications has

Advantages of an Ethernet-Based Solution

By converging on Ethernet as the method of communication across the enterprise, control- and field-level in process automation, the need for complex and power-hungry gateways has been removed. This also enables a transition from the hugely fragmented field bus infrastructure that has created data islands

where access to the data within field-level devices is limited. By removing these gateways, the cost and complexity of these legacy installations is significantly reduced and the data islands they created are removed.

Process automation applications, to-date, have used the legacy communications standards shown in Table 1, which have several limitations that the new 10BASE-T1L standard overcomes. There is also a knowledge base challenge within process automation. Through retirement, technicians and engineers are leaving the workforce and taking with them the detailed knowledge of how to deploy, debug, and maintain installations of 4 mA to 20 mA with HART® or field bus communications systems. College graduates are not familiar with these legacy technologies, but are very familiar with Ethernet-based technology and can quickly ramp up Ethernet-based networking solutions.

Table 1. 4 mA to 20 mA with HART vs. Field Bus vs. 10BASE-T1L

Comparison	4 mA to 20 mA with HART	Field Bus	10BASE-T1L
Data Bandwidth	1.2 kbps	31.25 kbps	10 Mbps
Higher Level Ethernet Connectivity	Complex gateways	Complex gateways	No gateways, seamless connectivity
Power to Instrument	<40 mW	Limited power	IS: 500 mW non IS up to 60 W (cable dependent)
Knowledge/Expertise	Shrinking knowledge/expertise	Shrinking knowledge/expertise	Ethernet technology is very familiar to all college graduates

Ethernet standards ensure that all higher protocol layers with 10BASE-T1L work exactly as with 10BASE-T, 100BASE-TX, and 1000BASE-T, eliminating the need for complex gateways. IEEE 802.3 is where all physical layers in the ISO 7-layer model are defined for Ethernet: 10BASE-T1L (see Figure 2). This means that devices can now use the PROFINET®, EtherNet™/IP, HART/IP, OPC UA™, or MODBUS®/TCP and support IoT protocols such as MQTT, which offers a simple yet powerful way to connect a field device to the cloud. Ethernet also enables simple, centrally controlled software updates right down to the end nodes, which enables faster network commissioning.



10BASE-T1L

Figure 3. Field-level device connectivity with a 10BASE-T1L PHY.

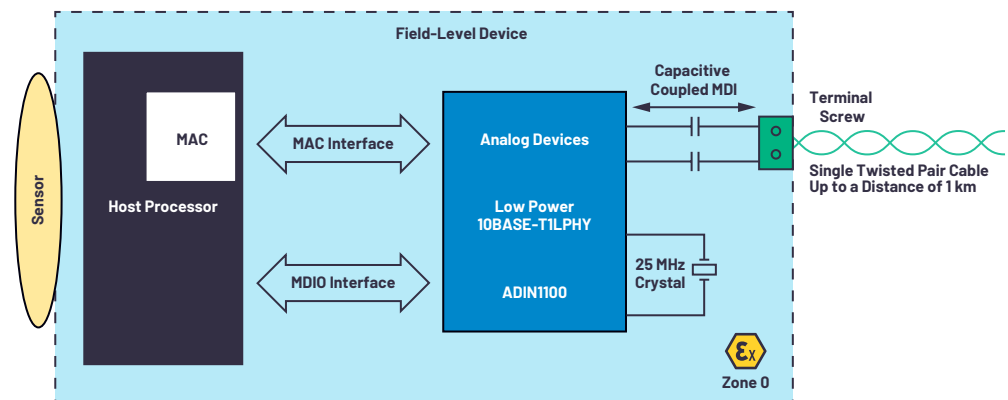

Layer	Type	OSI Model	TCP/IP Model	Authority
7	Data	Application Layer	Application Layer	RFCs, IETF, Industry Organizations, etc.
6	Data	Presentation Layer		
5	Data	Session Layer		
4	Segments	Transport Layer	TCP/UDP	
3	Packets	Network Layer	IP	
2	Frames	Data Link Layer	Ethernet Data Link	IEEE 802.1
1	Bits	Physical Layer	Ethernet 10BASE-T1L	IEEE 802.3

Figure 2. 10BASE-T1L in the ISO 7-layer model.

To communicate with a 10BASE-T1L enabled device, a host processor with integrated medium access control (MAC), a passive media converter, or a switch with 10BASE-T1L ports is required. No additional software, no customized TCP/IP stack, and no special drivers are required (see Figure 3). This results in clear advantages for 10BASE-T1L devices:

- ▶ Although a media converter is required for the connection of 10BASE-T1L, it only converts the physical encoding, not the content of the Ethernet packets. From the point of view of software and communication protocols, it is transparent.
- ▶ With Ethernet connectivity, it is possible to configure sensors with a laptop or mobile phone, regardless of whether the sensor is on the desk or is deployed in a manufacturing plant. For example, a temperature transmitter today has an additional interface (for example, in the form of USB), in order to be able to configure the converter. Depending on the manufacturer, there are well over 100 adjustment options. These parameters are simply not accessible today via 4 mA to 20 mA. HART allows access but is often unavailable for cost reasons. So, if a mistake was made during setup at the desk, a 4 mA to 20 mA sensor would need to be reconfigured after installation on site. A sensor connected with 10BASE-T1L is accessible over the network and can be remotely updated anywhere, at any time.
- ▶ The 4 mA to 20 mA devices can only transfer one process value. Ethernet provides direct access not only to process values but to all device parameters such as asset management, life cycle management, predictive maintenance, configuration, and parameterization.

- ▶ Sensors are becoming more complex and the probability of software updates increases. This is now possible within realistic periods of time via a fast Ethernet connection, anywhere, anytime.
- ▶ Access to advanced Ethernet network diagnostic tools to simplify root cause analysis.

Process Automation Cabling and Network Deployment

In process automation, unlike in machine building or factory automation, these sensors and actuators (flow, level, pressure, and temperature) do not sit close to the controller. Distances of 200 m between sensors and I/O are not uncommon and from there it can be up to 1000 m between field switches. Process automation uses a Type A field bus cable, as it is already used for PROFIBUS PA and Foundation Fieldbus installations today.

The 10BASE-T1L standard does not define a specific transmission medium (cable); instead, it defines a channel model (return loss and insertion loss requirements). The 10BASE-T1L channel model fits well with a field bus type A cable, therefore some installed 4 mA to 20 mA cables can potentially be reused with 10BASE-T1L, creating significant opportunities for brownfield upgrades of process automation installations.

As 10BASE-T1L allows the signal amplitude voltage to be reduced to 1 V on lines of up to approximately 200 m, 10BASE-T1L can be used in the environment of explosion-proof systems and meet the strict maximum energy restrictions of hazardous areas with up to 500 mW of power.

With the significant increase in power compared to 4 mA to 20 mA (500 mW vs. ~36 mW), today's 4-wire devices that require an external power supply due to the limited power of 4 mA to 20 mA can now be replaced with 2-wire devices enabled by 10BASE-T1L, providing more installation flexibility for new devices by removing the need for an external power supply.

Figure 4 shows the proposed network topology of the process industry, referred to as a trunk and spur network topology. The trunk cables can be up to 1 km with a PHY amplitude of 2.4 V peak-to-peak and reside in Zone 1, Division 2. The spur cables can be up to 200 m in length with a PHY amplitude of 1.0 V peak-to-peak and reside in Zone 0, Division 1. A power switch resides at the control level, provides Ethernet switch functionality, and supplies the power to the cable (over the data lines). Field switches reside at the field level in the hazardous area and are powered by the cable. The field switches provide the Ethernet switch functionality that connects the field-level devices on the spurs to the trunk and pass the power to the field-level devices. Multiple field switches are connected on a trunk cable to provide for the high numbers of field-level devices to be connected to the network.

The field switches can be connected via a ring topology to enable redundancy. At the edge, up to 10 Mbps is a major advance for most applications that were previously limited to a data rate of less than 30 kbps. As Ethernet is now used to connect the end node devices at the field level, the IT and OT have successfully been converged onto a seamless Ethernet network, enabling IP addressability to any end node device from anywhere in the world.

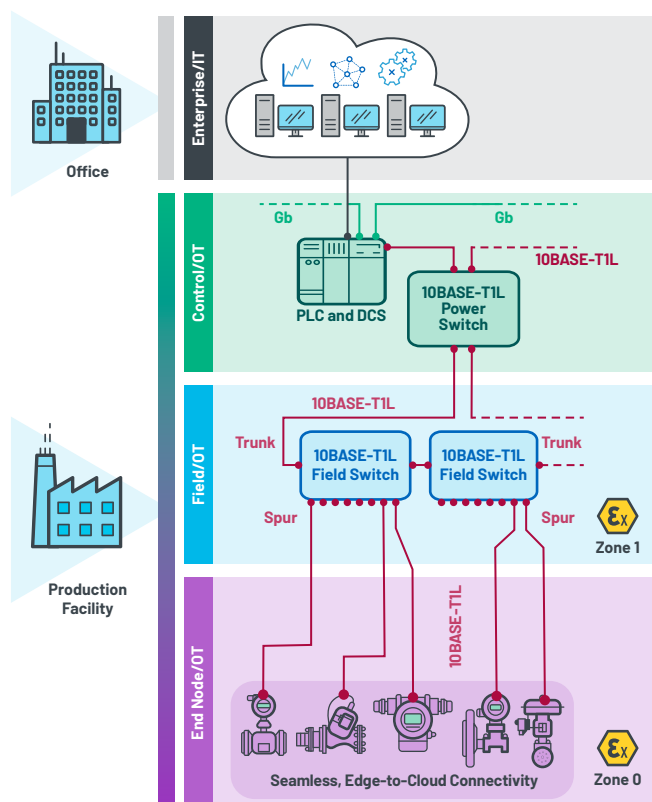

Figure 4. 10BASE-T1L network topology for the process industry.

Ethernet-APL with 10BASE-T1L

Ethernet-APL (advanced physical layer) specifies the details of the application of Ethernet communication to sensors and actuators for the process industry and will be published under the IEC. It is based on the 10BASE-T1L Ethernet physical layer standard and specifies the implementation and explosion protection methods for use in hazardous locations. The leading companies in process automation are working together under the umbrella of PROFIBUS and PROFINET International (PI), ODVA, Inc., and FieldComm Group® to make Ethernet-APL work across Industrial Ethernet protocols and to accelerate its deployment.

Process Automation: A Transition to Future Seamless Ethernet Connectivity

The 4 mA to 20 mA connection with HART has been successfully deployed in process automation applications for many years and is a proven, robust solution that will not disappear overnight. There is a large, existing install base of 4 mA to 20 mA with HART-enabled instruments and Analog Devices is investing in software configurable I/O, which enables more installation flexibility for these existing devices by allowing any industrial I/O function to be accessed on any pin, allowing channels to be configured at any time in remote I/O applications. This means customization can happen right at the time of installation, resulting in faster time to market, fewer design resources, and universal products that can be leveraged broadly across projects and customers. Examples of software programmable I/O circuits from Analog Devices are the [AD74413](#) and the [AD4110-1](#).

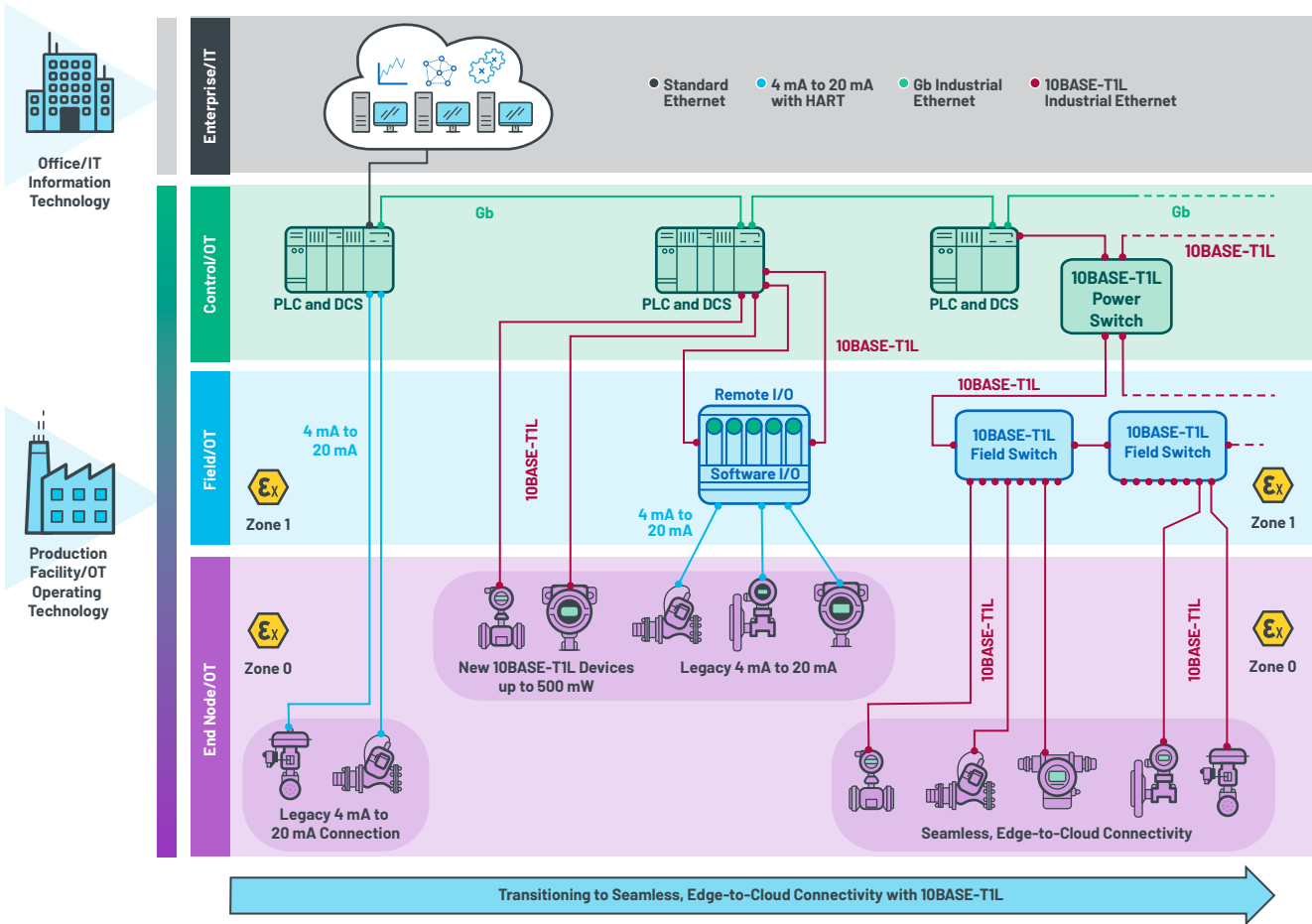

Figure 5. Legacy discrete wiring will gradually become a smart Ethernet network of all sensors and actuators.

Figure 5 shows the transition from legacy 4 mA to 20 mA connected instruments to a brownfield Ethernet, where new 10BASE-T1L-enabled instruments will coexist with legacy 4 mA to 20 mA instruments. Software configurable I/O connects these legacy instruments where remote I/Os provide the aggregation point to a 10 Mb Ethernet uplink to the PLC.

Seamless, edge-to-cloud connectivity will be achieved in process automation with 10BASE-T1L technology. 10BASE-T1L removes the need for gateways and I/O, as well as enables Ethernet connectivity from the field devices to the control level and eventually to the cloud. Unlocking field devices will result in rich datasets for advanced data analytics.

10BASE-T1L Applications Beyond Process Automation

10BASE-T1L is now gaining significant traction in building automation, factory automation, energy supply, monitoring, automation of waterworks and wastewater treatment, and, finally, elevators. All these applications share the requirements for higher bandwidth, seamless Ethernet connectivity (no gateways) to the sensor, on a single twisted pair cable supporting both power and data. Table 2 compares 10BASE-T1L with the incumbent wired technologies used today. Application examples include RS-485 used in building automation and I/O link used in factory automation.

10BASE-T1L Devices Create Actionable Insights to Drive Process Optimization

With the addition of 10BASE-T1L physical layer products to Analog Devices' Chronous™ portfolio of Industrial Ethernet solutions, ADI will enable the transition to field-to-cloud connected process automation installations, including hazardous locations for food and beverage, pharmaceutical, and oil and gas installations. New 10BASE-T1L physical layer transceivers will provide the physical layer interface to unlock the many advantages of an Ethernet connected plant. With 10BASE-T1L, Ethernet packets move from the field level to the control level, and eventually to the cloud, without gateways, realizing the goals of an Industrial 4.0 unified IT/OT network. With significantly more power available, new types of field devices with enhanced features and functions can be enabled. Transparent IP addressability of each field-level device will dramatically simplify the installation, configuration, and maintenance of 10BASE-T1L connected instruments. 10BASE-T1L will unlock new field devices, rich datasets for cloud computing, and advanced data analytics. Plant operational efficiency will be increased through the access of actionable insights from their processes, accelerating the deployment of more complex process automation production facilities in the future.

For more information on the ADI Chronous portfolio of Industrial Ethernet solutions and how they are accelerating the transition to real-world Industrial Ethernet networks, please visit analog.com/chronous.

Table 2. Comparison of Existing Communications Standards with 10BASE-T1L

Protocol	Packet Formats	Cable Length	Bit Rate	Power Supply via Data Cable	Connector	Intrinsic Safe Use Case
PROFIBUS PA	UART/PROFIBUS	1200 m	31.25 kbps, bus, half duplex	Yes	M12, terminal screw	Yes
Modbus RTU and Other RS-485 Protocols	UART/Modbus	1200 m (up to approximately 185 kbps, at 375 kb 300 m, at 500 kb, 200 m)	Typically 19.2 kbps, bus, half duplex	No	DB9, M12	N/A
I/O Link	I/O link	20 m	Max 230.4 kbps, half duplex	No	M12	No
4 mA to 20 mA	Analog interface	>10 km	-/-	Yes, 36 mW	Screw	Yes
HART	Digitally modulated over 4 mA to 20 mA	>1500 m	1200 bps, bus, half duplex	Yes, 36 mW	Screw	Yes
10BASE-T1L	Ethernet IEEE 802.3	1000 m (2.4 V) with up to 10 joints (terminal boxes) >200 m (1.0 V)	10 Mbit, full duplex	Yes, up to 60 W In Ex Zone 0 up to 500 mW	Terminal screw or IDC connector, optional single pair Ethernet connector	Yes

About the Authors

Maurice O'Brien is the strategic marketing manager for industrial connectivity at Analog Devices. He is responsible for the strategy supporting Industrial Ethernet connectivity solutions for industrial applications. Prior to this role, Maurice spent 15 years working in applications and marketing roles in power management with Analog Devices. He has a Bachelor of Engineering degree in electronic engineering from the University of Limerick, Ireland. He can be reached at maurice.obrien@analog.com.

Volker E. Goller is a systems applications engineer with Analog Devices and has over 30 years of experience with a diverse set of industrial applications ranging from complex motion control and embedded sensors to time sensitive networking technology. A software developer by trade, Volker has developed a wide variety of communication protocols and stacks for wireless and wired applications while actively engaging in fielding new communication standards through his involvement in leading industry organizations. He can be reached at volker.goller@analog.com.

Engage with the ADI technology experts in our online support community. Ask your tough design questions, browse FAQs, or join a conversation.



Visit ez.analog.com



AHEAD OF WHAT'S POSSIBLE™

For regional headquarters, sales, and distributors or to contact customer service and technical support, visit analog.com/contact.

Ask our ADI technology experts tough questions, browse FAQs, or join a conversation at the EngineerZone Online Support Community. Visit ez.analog.com.

©2020 Analog Devices, Inc. All rights reserved. Trademarks and registered trademarks are the property of their respective owners.

TA22247-7/20(A)

VISIT ANALOG.COM