



We drive efficiency in drives

Our expertise for your optimal drive systems

March 2021



Agenda

- 1 Introduction
- 2 A closer look on inverter solutions
- 3 Product solutions overview
- 4 Benefits with Silicon Carbide solutions (SiC)
- 5 IGBT7 technology – features and benefits
- 6 Key take-aways
- 7 Further information and links

Agenda

- 1 Introduction
- 2 A closer look on inverter solutions
- 3 Product solutions overview
- 4 Benefits with Silicon Carbide solutions (SiC)
- 5 IGBT7 technology – features and benefits
- 6 Key take-aways
- 7 Further information and links

Application web page update

Industrial Drives



Low Voltage Drives

- > General purpose drives
- > Servo drives
- > C-HVAC

Medium Voltage Drives

- > Medium Voltage Drives

Industrial motor types

- > Induction motor
- > Switched reluctance motor
- > Permanent magnet synchronous motor
- > Servo motor
- > Brushed DC motor
- > Brushless DC motor

Industrial automation

- > Industrial automation

Overview of three major areas in low voltage drives

General and purpose drives

370 W

1250 kW

Requirements

- > Performance and reliability
- > Safety features
- > Good price / performance ratio

Key applications

- > Pumps & fans
- > Process automation
- > Cranes
- > Marine drives

Infineon products

- > iMOTION™
- > CIPOS™ IPM
- > EiceDRIVER™ gate driver
- > EasyPIM™
- > EconoPIM™
- > EconoDUAL™
- > PrimePACK™
- > CoolSiC™
- > MOSFETs

Servo drives

370 W

315 kW

Requirements

- > High positioning accuracy
- > Fast response with no overshoot
- > High reliability

Key applications

- > Robotics
- > Material handling
- > Machine tools

Infineon products

- > CIPOS™ IPM
- > Discretet
- > EiceDRIVER™ gate driver
- > EconoPACK™
- > EasyPACK™
- > EconoDUAL™
- > CoolSiC™
- > MOSFETs

C-HVAC

3 kW

75 kW

Requirements

- > Good price / performance ratio

Key applications

- > Commercial Heating & Ventilation Air-Conditioning (C-HVAC)

Infineon products

- > EconoPIM™
- > EasyPIM™
- > EiceDRIVER™ gate driver
- > OPTIGA™ Trust family
- > CIPOS™ IPM
- > iMOTION™

Overview of medium voltage drives

Medium voltage drives

250 kW

36 MW

Requirements

- > Long life cycle
- > Fast repair
- > Redundancy
- > High efficiency

Key applications

- > Water pumps
- > Material handling
- > Power generation
- > Oil & gas

Infineon products

- > PrimePACK™
- > PrimePACK™ .XT
- > XHP™ 2
- > XHP™ 3
- > EconoDUAL™
- > 62mm
- > EiceDRIVER™ gate driver



Agenda

- 1 Introduction
- 2 A closer look on inverter solutions
- 3 Product solutions overview
- 4 Benefits with Silicon Carbide solutions (SiC)
- 5 IGBT7 technology – features and benefits
- 6 Key take-aways
- 7 Further information and links

Key questions to design your drives inverter

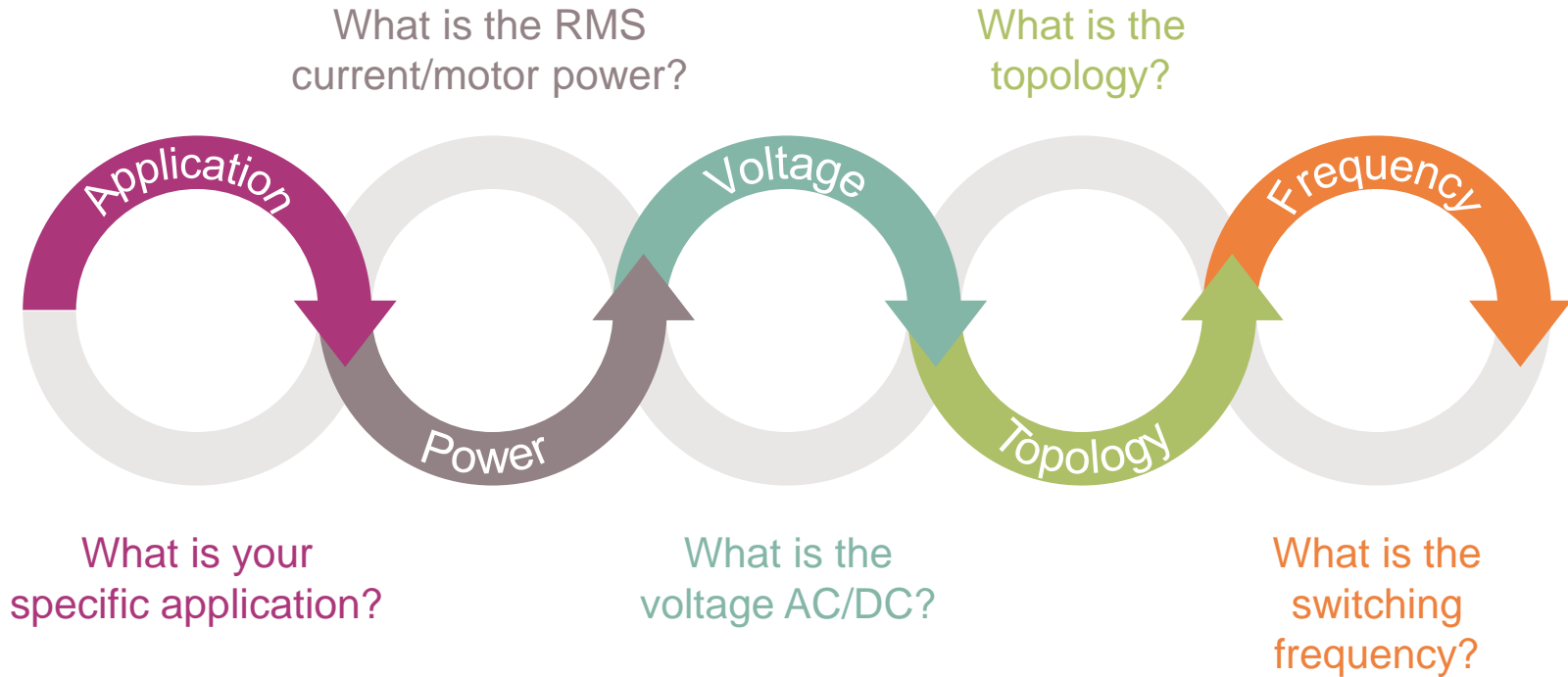

A closer look to a typical converter system

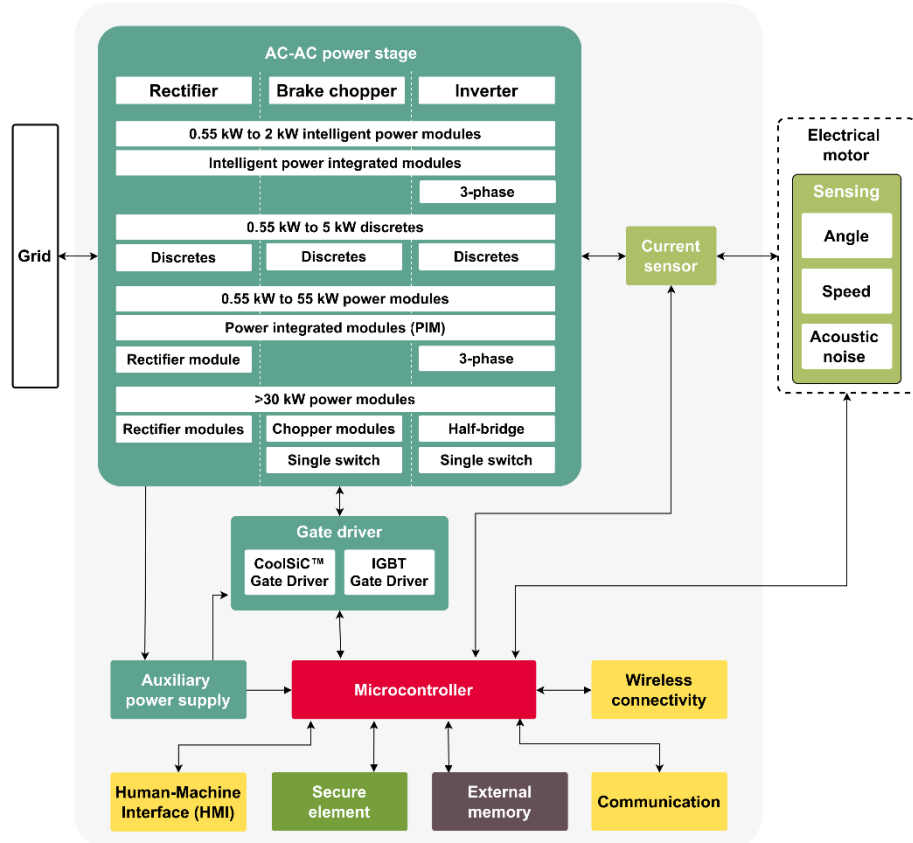

The levels of integration

Power electronics

- › Discretes
- › 3-phase PIM
- › Sixpack
- › Dual switch
- › Single switch
- › Thyristors & Diode Discs

Gate drivers

- › Level shift driver
 - › High side
 - › Half bridge
 - › High and low side
 - › Three phase
- › Isolated driver (1 & 2 channel)
- › Low side driver (1 & 2 channel)

Sensors & Security

- › Magnetic sensor for position and speed
- › Current sensor
- › OPTIGA™ Trust family

Microcontrollers

- › XMC™ controller family based on ARM® Cortex®-M
- › Countless possibilities for motor control

Wireless connectivity

- › Wi-Fi MCUs

External memory

- › High-Performance Memories for Embedded Systems
 - › Flash
 - › RAM

Application requirements for general purpose, servo and C-HVAC drives

	General purpose drives	Servo drives	C-HVAC	
Power	Broad portfolio (0.37... 1250 kW) 600 V, 1700 V and 1200 V switches (major)	Less broad portfolio (... ~315 kW or <u>customized current classes</u>) 600 V, 1200 V switches (major)	Portfolio (3 kW to 75 kW) 1200 V switches	
f_{sw}	4 to 8 kHz <100 kW 2 to 4 kHz >100 kW	4 to 8 kHz, 16 kHz w/ derating	4 to 8 kHz	
dv/dt	$\leq 5 \text{ kV}/\mu\text{s}$			
SC	Fast short circuit detection (e.g. 8 μs for IGBT)			
f_{out}	a) Light duty – 50/60 Hz b) Heavy duty 1Hz w/ derating	Low f_{out} common down to 0 Hz (locked rotor)	30 Hz to 250 Hz	
OL	a) Light duty e.g. 110% I_N 60 sec 100% I_N 240 sec b) Heavy duty e.g. 150% I_N 60 sec 100% I_N 240 sec	a) High overload e.g. 200% I_N 3 sec 0% I_N 7 sec b) Very high overload e.g. 300% I_N 0.25 sec 70% I_N 3.75 sec	No overload / light overload	

Overload ratings for low-voltage drives are key for reliability

Overload capability is the property in which, during acceleration operations, the inverter temporarily delivers a higher current than the rated current. **There are two sorts of ratings used in industrial drives:**

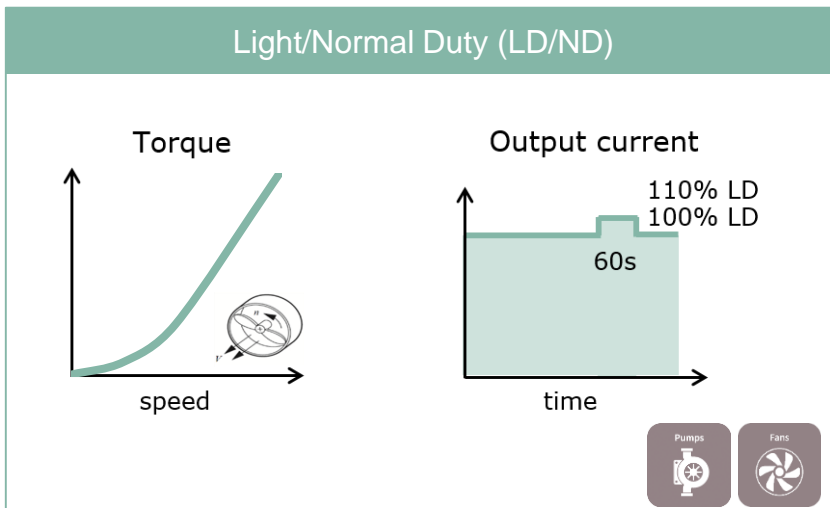

- › Applied in fans and pumps, since they do not require high torque at low speed and have a 110% overload rating

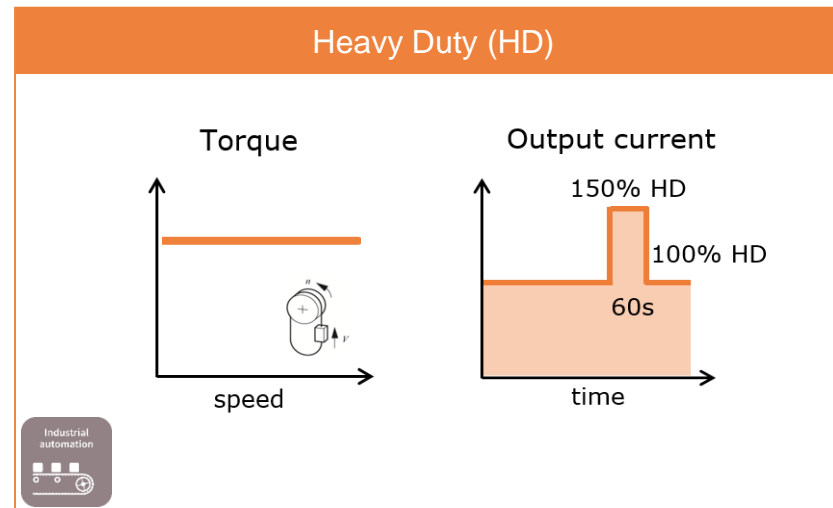

- › Applied in industrial automation and requires high torque at low speeds and a 150% overload rating
- › The base load current is reduced when compared to normal duty

For servo drives the overload capability can increase up to 300% of rated current.

Agenda

- 1 Introduction
- 2 A closer look on inverter solutions
- 3 **Product solutions overview**
- 4 Benefits with Silicon Carbide solutions (SiC)
- 5 IGBT7 technology – features and benefits
- 6 Key take-aways
- 7 Further information and links

Broad IPM portfolio serving power ranges from 20 W to 8 kW

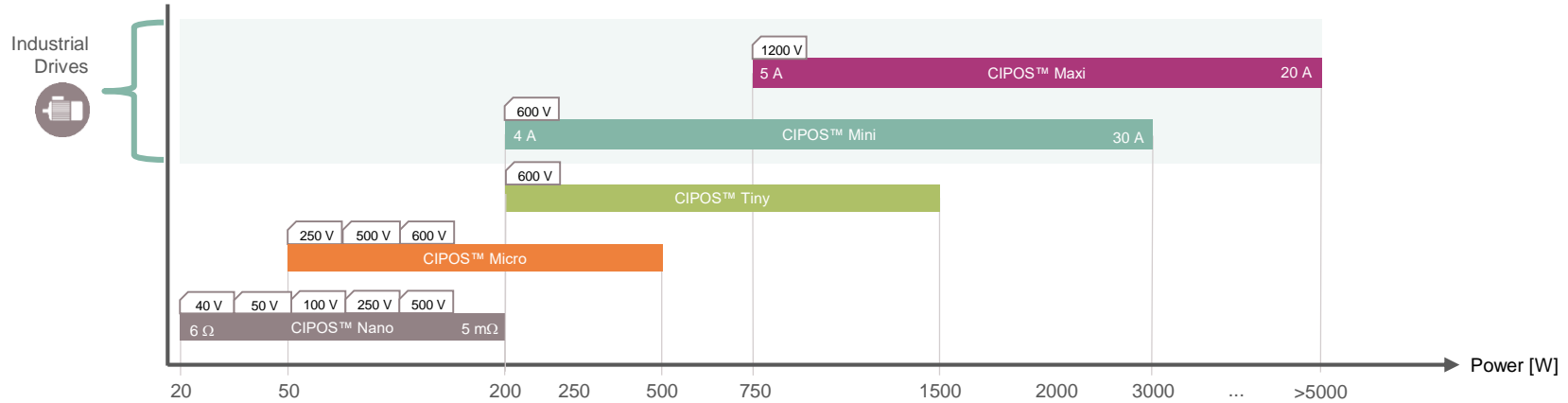

CIPOS™ Nano



- > For space constrained applications
- > Powering millions of personal cares and low power application

CIPOS™ Micro

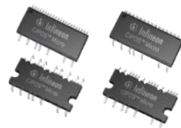

- > Compact solution
- > Optimized solution for low power fan & pump

CIPOS™ Tiny

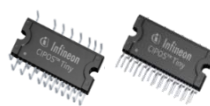

- > New solution for better design flexibility
- > Optimized solution for BLDC motor in HVAC

CIPOS™ Mini

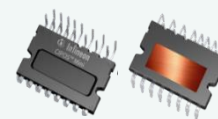

- > Broad range portfolio
- > Proven solution for MHA/Industrial drives

CIPOS™ Maxi

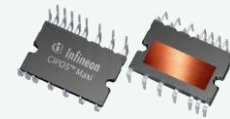

- > Highest power density
- > Ruggedized Industrial drives and CAC solution

CIPOS™ Mini provides fully featured compact inverter solution with wide current range up to 30 A

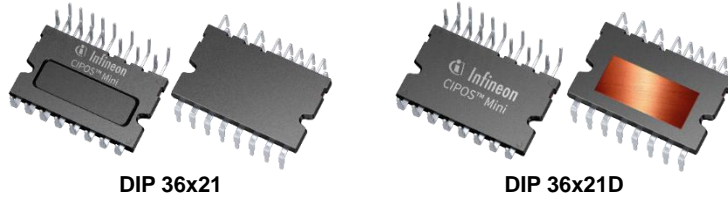

DIP 36x21

DIP 36x21D



Key features

- › Fully isolated dual-in-line transfer molded package
- › Compact body size of 36x21x3.1mm and the smallest IPM with current rating up to 30 A
- › One package platform covers wide current rating from 4 A to 30 A and it allows easy & fast platform design from small to larger power.
- › Two kinds of package types: DIP 36x21 with fullpack and DIP 36x21D with DCB substrate to support excellent thermal performance
- › Integrated 600V TRENCHSTOP™ IGBT and rugged SOI gate driver technology with advanced protection features
- › UL certified



Internal schematic and products

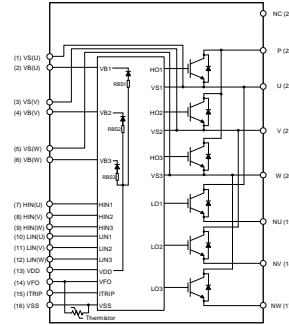

Product name	Related Current [A]	Package
IKCM10L60GA	10 A	DIP 36x21
IKCM15L60GA	15 A	
IKCM20L60GA	20 A	
IKCM15L60GD	15 A	DIP 36x21D
IKCM20L60GD	20 A	
IM535-U6D	30 A	



Benefits

- › High integrations (bootstrap circuit, thermistor) for easy design and saving system space
- › Single platform possible from 4 A to 30 A
- › Enhanced robustness of the advanced IGBT, gate driver IC technology
- › Smaller package and high power density
- › Two kinds of substrates provide cost efficient solution for low to medium power motor drives.

<https://www.infineon.com/cms/en/product/power/intelligent-power-modules-ipm/cipos-mini/>

CIPOS™ Mini single boost PFC-integrated 3 phase inverter IPM enables system size reduction and cost improvement

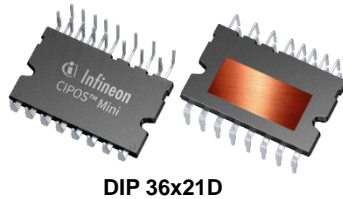

Exemplary schematic/topology:

IFCM10/15S/P60GD

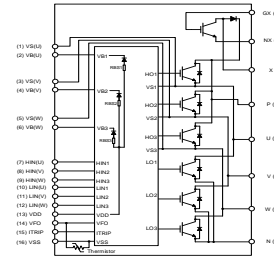

IM564-X6D

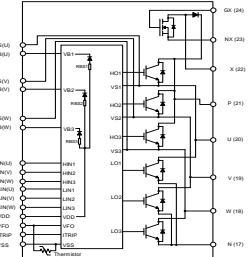

Rated current	PFC Fsw	
	20 kHz	40 kHz
10 A	IFCM10S60GD	IFCM10P60GD
15 A	IFCM15S60GD	IFCM15P60GD
20 A	IM564-X6D (over 100 kHz with CoolMOS™ for PFC)	



Key features

- > Fully isolated dual-in-line transfer molded package
- > Excellent thermal performance with DCB substrate
- > Inverter + single boost PFC in one package
- > Inverter current rating : 10 / 15 / 20A
- > Various PFC switching available : 20 kHz or 40 kHz (for 10 / 15 A)
- > High PFC switching over 100kHz with CoolMOS™ Power MOSFET for PFC (for 20 A)
- > Robust gate driver in SOI technology
- > Power capability over 2 kW
- > UL certified



Benefits

- > System size reduction with PFC integration into inverter module as well as significant inductor size reduction with high PFC switching
- > Cost improvement from lower BOM count, reduced assembly cost, and smaller system size
- > Smaller and cheaper heatsink
- > Customer can design switching performance of PFC by using external driver circuit

<https://www.infineon.com/cms/en/product/power/intelligent-power-modules-ipm/im564-x6d/>

CIPOS™ Maxi IPM Provide Excellent Performance with Highest Power Density in 1200 V Class for 3-Phase Motor Drive Application



DIP 36x23D

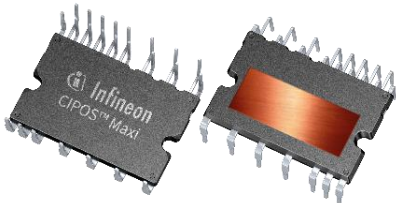

Key features

- › Offers the smallest package in 1200 V IPM class
- › Integrated 6 TRENCHSTOP™ IGBT 4 / CoolSiC™ MOSFET and a rugged 1200 V 6-channel SOI gate driver
- › Integrated bootstrap functionality
- › Over current shutdown
- › Under-voltage lockout at all channels
- › RFE pin with multi-functions
- › An independent thermistor for temperature monitoring



Exemplary schematic/topology:

Part No.	Package	Rds(on)/ Current Rating	Voltage Rating	Ver.
IM818-SCC	DIP 36x23D	5 A	1200 V	IGBT 4
IM818-MCC	DIP 36x23D	10 A	1200 V	IGBT 4
IM818-LCC*	DIP 36x23D	15 A	1200 V	IGBT 4
IM828-XCC	DIP 36x23D	55 mohm / 20 A	1200 V	CoolSiC™ MOSFET

*) Under development

› 3-phase inverter

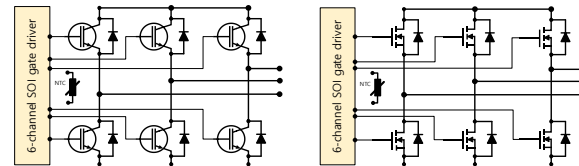

Benefits

- › The smallest package size in 1200 V IPM class with high power density
- › High output power up to 8 kW
- › High efficiency up to 99.6%
- › Enhanced robustness of gate driver technology for excellent protection
- › Adapted to high switching application with lower power loss
- › Simplified system design and manufacturing

Broad discrete IGBT & SiC portfolio serving power ranges up to 20 kW

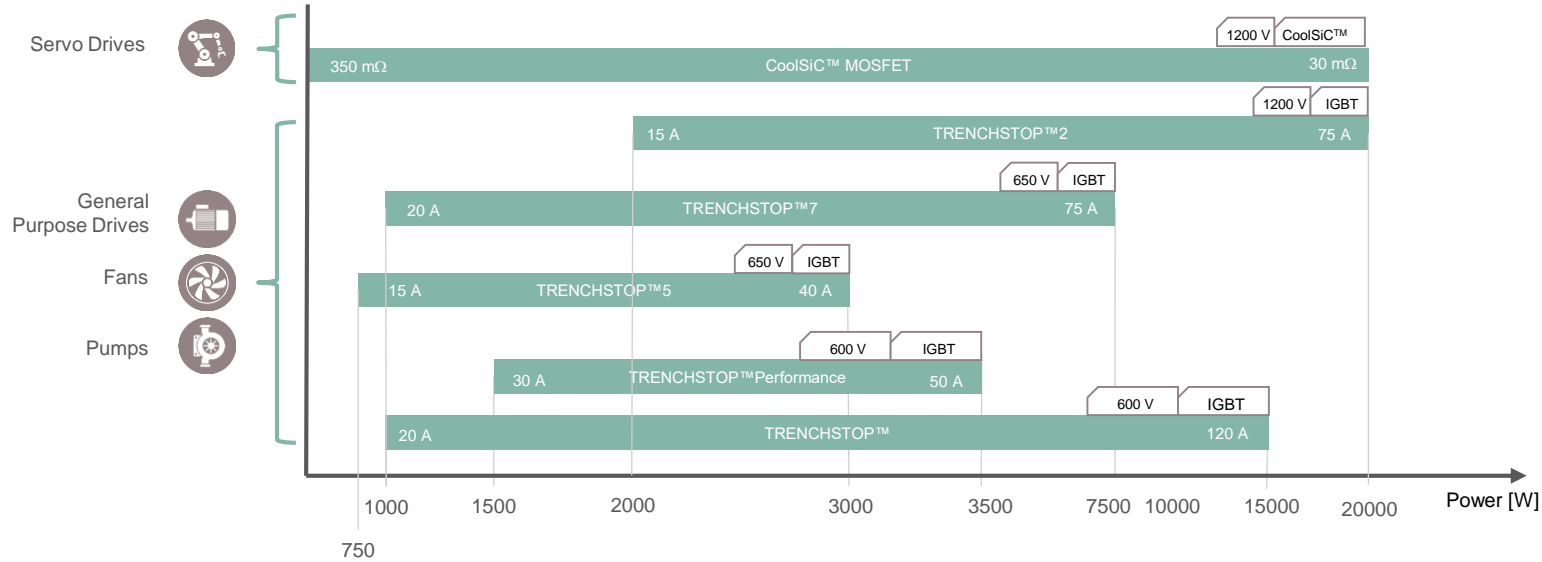

Discrete IGBT and CoolSiC™ MOSFET portfolio



Discrete solutions for industrial drives – features and benefits

Product type	Input Connection	Product name and Family
INV Switch-IGBT	1-phase	IKW50N65ET7 TRENCHSTOP™ IGBT7 or IMW65R072M1H CoolSiC™ MOSFET
	3-phase	IKW40N120H3 HighSpeed DuoPack
INV Switch-SiC MOSFET	3-phase	IMW120R060M1H CoolSiC™ MOSFET



Exemplary schematic/topology:

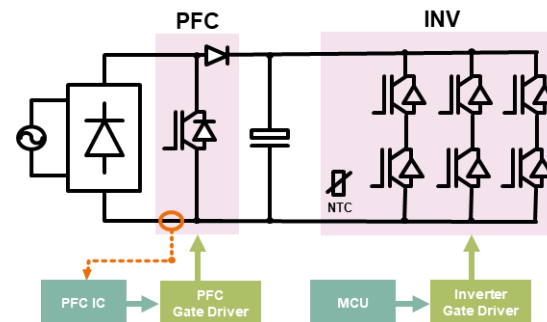

Key features

- > IGBT7 T7 show:
 - Improved humidity ruggedness
 - Low saturation and forward voltage
 - High collector emitter voltage at 650 V
 - Up to 5µs Short Circuit Withstand Time
- > CoolSiC™ MOSFET has:
 - Exclusive 3 µs short circuit withstand time
 - Reliability as Si power transistor by Infineon
 - Lowest total losses at the same EMI level as IGBT

Benefits

- > CoolSiC™ MOSFET provides:
 - Minimum switching losses, maximum cooling surface area, zero-voltage turn-off, minimized PCB board space and further power density improvements
- > TRENCHSTOP™ IGBT7 is best in class device in motor drive applications, where it shows:
 - up to 25% Higher Power Density or up to 15% lower temperature rise

Broad IGBT package portfolio serving current ranges from 6 A to 3 kA

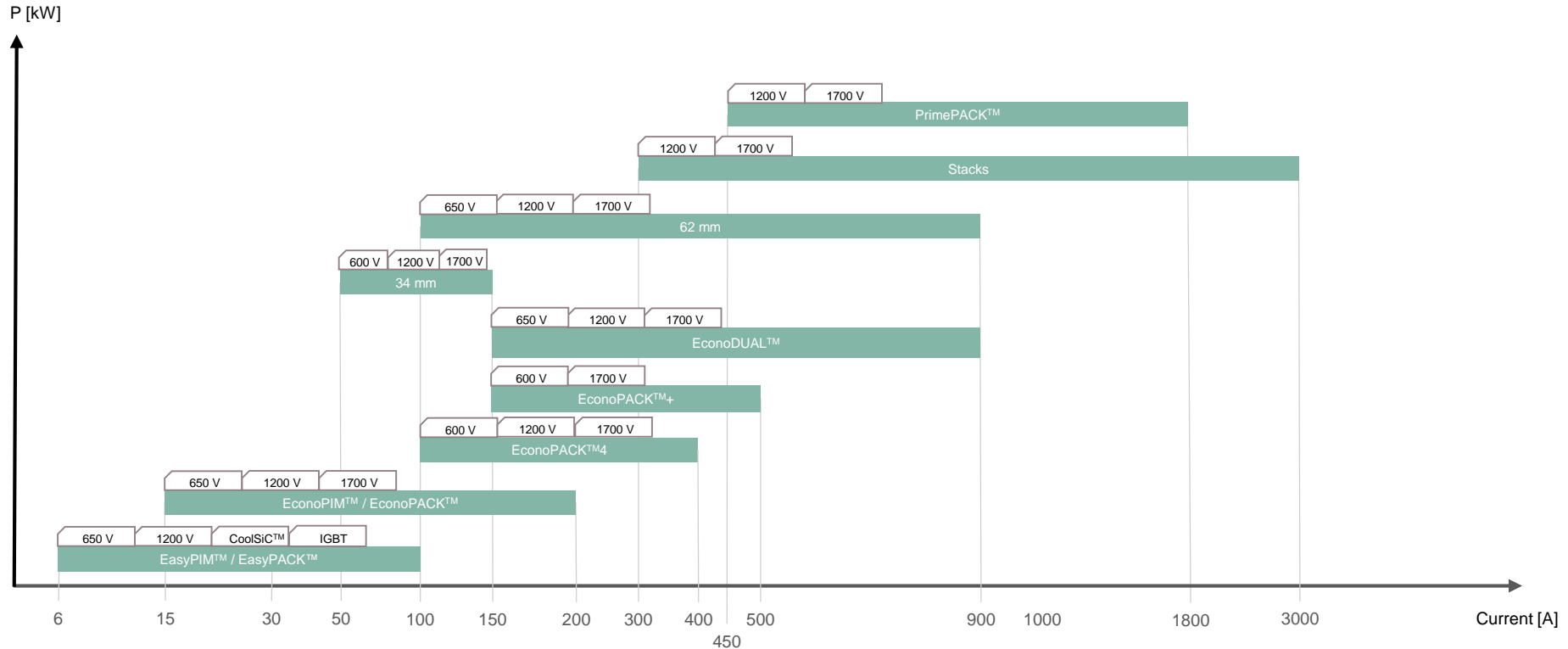

TRENCHSTOP™ IGBT7 with the Easy family – A perfect fit for platform based design of industrial drives



Exemplary schematic/topology:

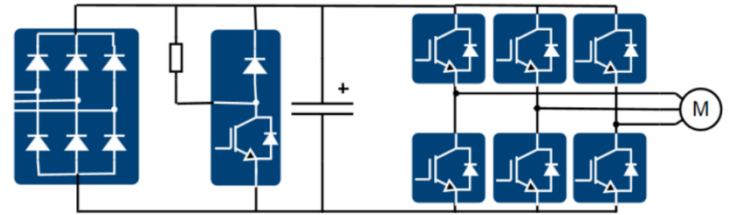

Key features

- › The latest TRENCHSTOP™ IGBT7 and EC7 diode technology
- › Lower on state voltage $V_{CE(sat)}$ and V_f
- › Overload capability at $T_{vj,op}=175^{\circ}C$
- › Enhanced controllability of dv/dt
- › Optimized for simple driving
- › All packages have same mechanical height

Find more for IGBT7: www.infineon.com/IGBT7

Find more for Easy modules: <https://www.infineon.com/cms/en/product/power/igbt/igbt-modules/easy/>



Benefits

- › **Higher power density** and lower power losses
- › Optimized for **Drives** application
- › Reduced system size and **lower system cost**
- › **Power extension** up to 45 kW, fit for platform based design and production

Easy modules with CoolSiC™ MOSFET chip technology for industrial drives



EasyPACK™ FS45MR12W1M1P_B11 also available with pre-applied TIM



Key features

EasyPACK™ 1B 1200 V / 4 mΩ sixpack module with CoolSiC™ MOSFET in 1200 V, NTC and PressFIT contact technology

- › High current density
- › Best in class switching and conduction losses
- › Low inductive design
- › Integrated NTC temperature sensor
- › PressFIT contact technology
- › RoHS-compliant modules



Exemplary schematic/topology:

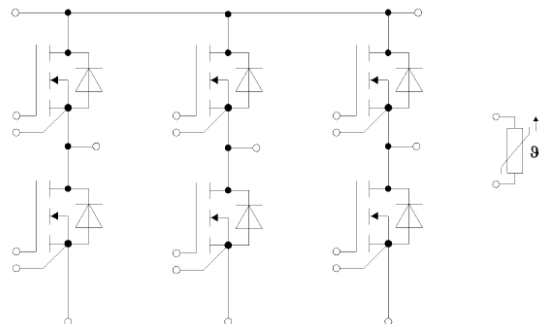

Benefits

- › Highest efficiency for reduced cooling effort
- › Higher frequency operation
- › Increased power density
- › Optimized customer's development cycle time and cost

Econo2 & Econo3 modules – established product for broad range of applications



Exemplary schematic/topology:

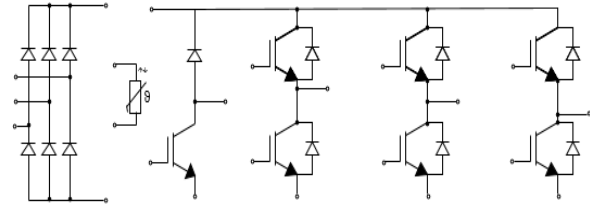

PIM with NTC



Key features

- › Established RoHS-compliant housing concept for high volume production
- › Modules with base plate for increased robustness in standard solder pins or high reliability PressFIT pins
- › Available with state-of-the-art IGBT7 technology
- › Numerous topologies, voltages (600V-1700V) and currents (15A-200A) for broad range of applications
- › Integrated configurations includes NTC, shunt, pre-applied Thermal Interface Material (TIM), Advance H2S protection



Benefits

- › High reliability and quality
- › Cost-efficient
- › Fast, simplified, low-cost mounting
- › Design flexibility and simple integration in power electronic applications
- › High power density

EconoDUAL™ 3 – 1st choice for future system designs



Exemplary schematic/topology:

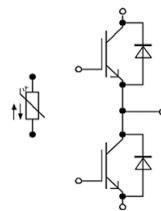

Half-bridge

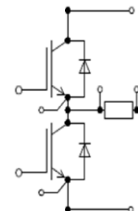

Half-bridge with shunts

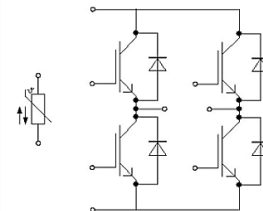

H-bridge



Key features

- > Highest power cycling capability
- > Excellent mechanical robustness
- > Screw-type power terminals and PressFIT control pins
- > TIM – pre-applied thermal interface material
- > Available with integrated shunts
- > NTC integration for temperature control
- > Evaluation Boards to reduce design-in effort
- > T_{vjop} 150°C (TRENCHSTOP™ IGBT4)
- > T_{vjop} 175°C overload (TRENCHSTOP™ IGBT7)



Benefits

- > Optimized thermal resistance to heat sink
- > Reduced mounting effort and increased interconnection reliability
- > Compact configurations with only 17 mm height
- > Parallel operation enabled by a symmetrical design
- > Reduced system costs
- > One module fits several applications

EconoPACK™ 4



Exemplary schematic/topology:

Product	I _c (A)	Topology
FS100R12PT4	100	
FS150R12PT4	150	
FS200R12PT4	200	



Key features

- › Robustness: rugged mechanical design with ultrasonic welded and injection-molded screw terminals
- › Easy assembly: pressFIT control pins and screw power terminals for completely solderless connections
- › Integration: compact rectifier, chopper, 6-pack and 3-level single-phase configurations with NTC



Benefits

- › **Cost advantage** compared to using 3 x 34mm modules / 62mm modules
- › Allows **more compact inverters** compared to using 3 x 34mm / 3 x 62mm modules

34mm and 62mm module family with its comprehensive portfolio offers more flexibility and highest reliability for successful Inverter Designs



Exemplary schematic/topology:

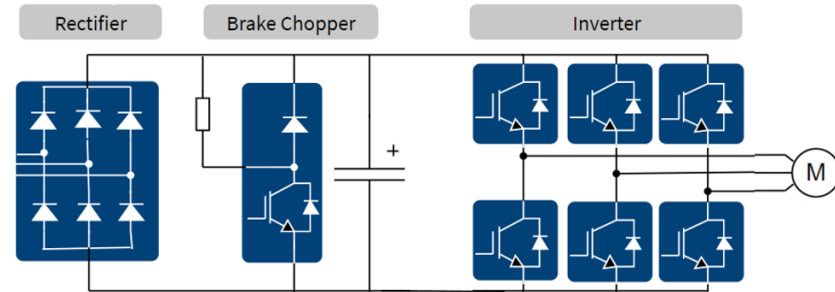

Key features

- > IGBT7 and EC7 1200V chipset
- > Superior solution for frequency controlled inverter drives
- > UL/CSA certification with UL1557 E83336
- > Operating temperature up to 150°C
- > Optimized switching characteristic
- > Softness
- > Existing packages with high current capability
- > RoHS compliant



Benefits

- > Highest power density
- > Allows to increase inverter output power with same frame size
- > Reduced switching losses
- > Improved humidity robustness

PrimePACK™ modules enable high system performance



PrimePACK™ 2: 172 x 89 mm



PrimePACK™ 3: 250 x 89 mm



Key features

- › Ultrasonic Welding between DCB and terminals for optimal mechanical and electrical interconnection
- › Equal distance between the chips and the mounting positions
- › Homogenous temperature distribution between the chips
- › Improved thermal resistance R_{thjc} by optimized chip locations
- › Fast switching (E4) and soft switching chips (P4)
- › Modular design optimized for paralleling
- › Pre-applied Thermal Interface Material (TIM) to achieve longest lifetime
- › NTC integration for temperature control
- › T_{vjop} 150°C



Exemplary schematic/topology:

Part Number	Voltage	IC [A]	Package	Topology
FF450R12IE4	1200 V	450	PP2	
FF600R12IE4/P4		600	PP2	
FF900R12IE4/P4		900	PP2	
FF1400R12IP4		1400	PP3	
FF450R17IE4	1700 V	450	PP2	
FF650R17IE4		650	PP2	
FF1000R17IE4		1000	PP3	
FF1400R17IP4		1400	PP3	



Benefits

- › Multiple frame sizes on single platform
- › Frame size scalability
- › High life time in demanding applications
- › High reliability and quality
- › Optimized system based costs
- › High $I_{rms}/Area$
- › High current terminals
- › Compact inverter size

Overview with performance classes for microcontroller

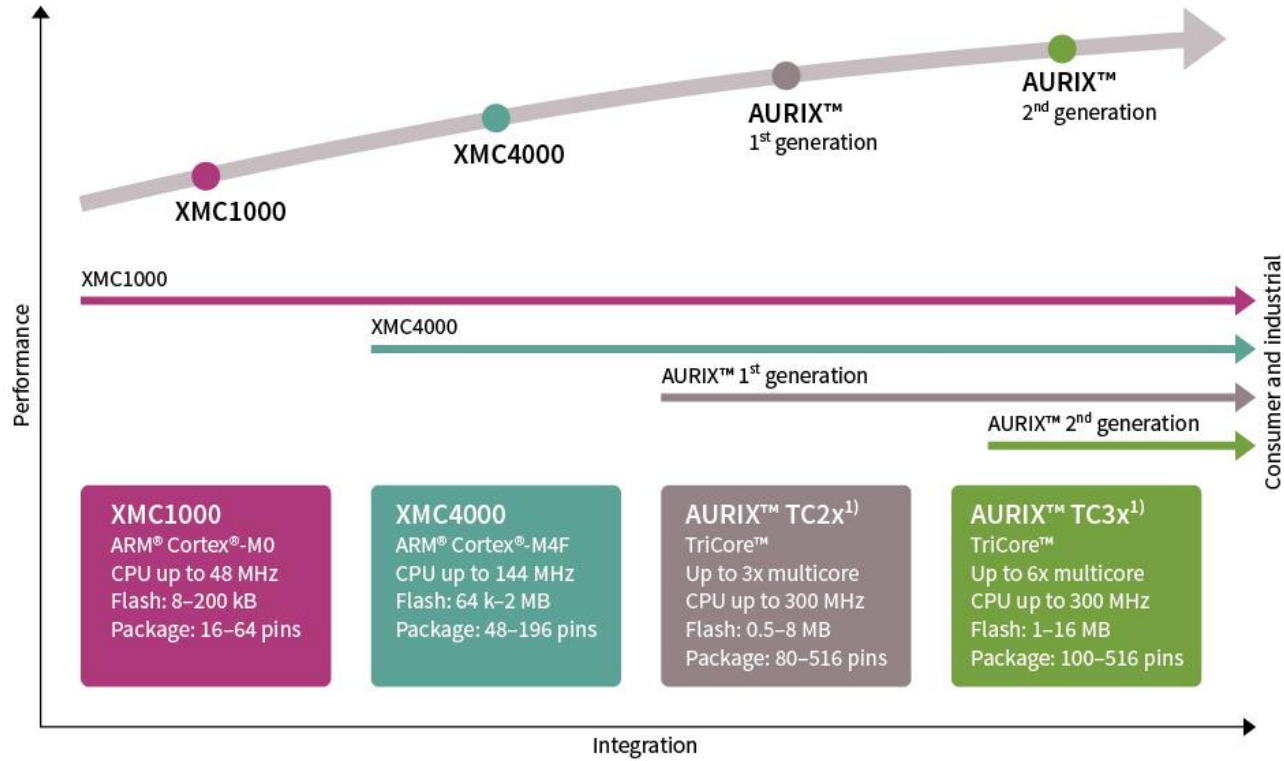

1) AURIX™ devices add safety and CAN FD

XMC™ microcontroller: The converter's brain

Tasks of the controller

- › IGBT control (PWM generation)
- › Motor feedback sensing (current, position, speed)
- › Speed, torque and position control
- › Communication (industrial Ethernet, CAN...)

Solutions for industrial drives

- › 32-bit ARM® Cortex™-M0 based XMC1000 family – low end
- › 32-bit ARM® Cortex™-M4F based XMC4000 family – mid range
- › 32-bit TriCore™ family – high end

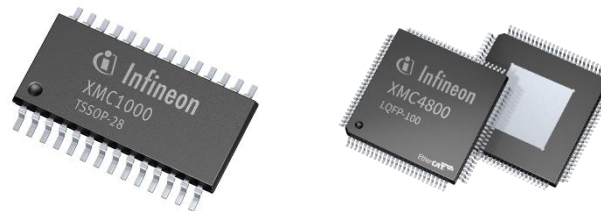

XMC4000 microcontroller units for industrial drives

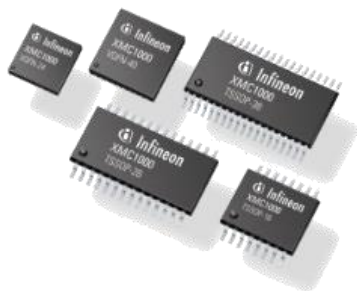

Key features

- > 32-bit ARM® Cortex™-M4 core with FPU running at 80MHz to 144MHz
- > Dedicated Inverter PWM generators (CCU8)
- > Fast and flexible 12-bit ADC
- > Interfaces for HALL sensors, encoders and resolvers
- > Event Request Unit (ERU)
- > EtherCAT interface
- > Wide temperature range from -40°C to 125°C



Exemplary schematic/topology:

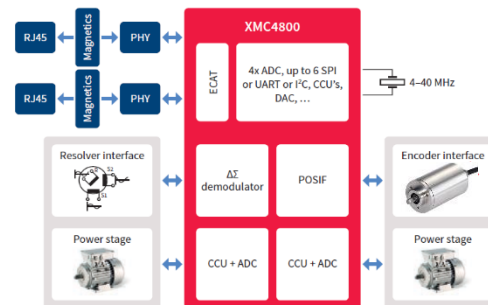

Benefits

- > Real-time performance combined with enhanced connectivity
- > Based on the robust technology going beyond usual industrial requirements
- > Motor Control Libraries and DAVE Apps for fast software development

ISOFACE™ product family – Galvanic isolation & diagnostics integrated

2nd
gen



> H823V 8x 0.6 A
12 x 12 VQFN

8-channel switch IC

- > 2.5 kV galvanic isolation
- > 3.3 V μ C interface (SPI, parallel)
- > Diagnostics per channel:
 - Open load
 - Short to V_{bb}
 - Short to GND & overload
 - Over temperature
- > 5-fold global diagnostics

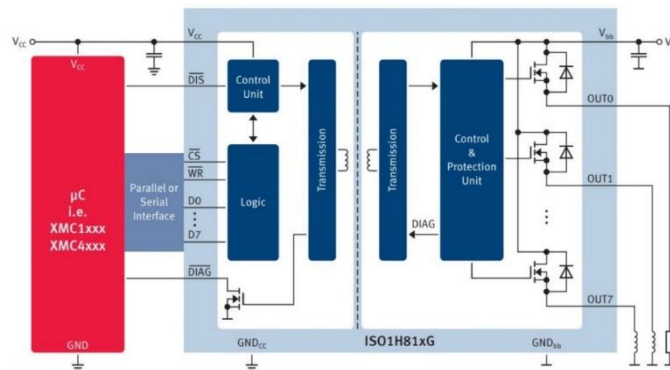

1st
gen



> H811G 8x 0.6 A Parallel
> H812G 8x 0.6 A SPI
> H815G 8x 1.2 A Parallel
> H816G 8x 1.2 A SPI

8-channel switch ICs

- > Integrated galvanic isolation
- > Direct interface to μ C
 - 3.3 V/5 V
 - Serial or parallel
- > Short-circuit protection
- > Inductive load switching
- > Up to 1.2 A load current
- > Integrated diagnostics:
 - Overload & short circuit

8-ch. digital input ICs

- > Integrated galvanic isolation
- > Direct interface to μ C
 - 3.3 V/5 V
 - Serial or parallel
- > IEC-input types: 1/2/3



	Sampling speed	Filter settings	Diagnostics
			V_{bb} -monitor Wire-break
> I811T	125 kHz	4 / IC	
> I813T	500 kHz	9 / channel	✓ ✓

8-channel switch ICs

8-channel input ICs

ISOFACE™ - Galvanic isolated high-side switches & input ICs



Key features

- > Integrated galvanic isolation
- > 8-channels
- > Integrated clamping diode
- > Programmable input filters
- > Diagnostic feedback



Exemplary schematic/topology:

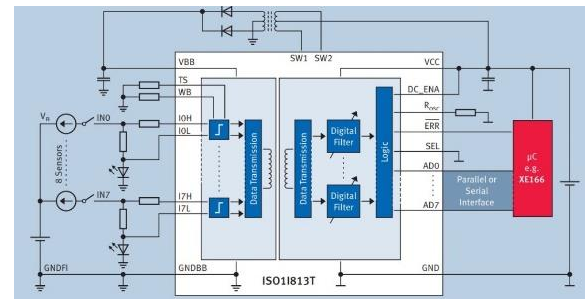

Benefits

- > Ideal for industrial applications operating at elevated temperatures
- > Higher operational life-time
- > Higher reliability
- > Ideal for high-precision or high-speed applications
- > At least 50% PCB area savings
- > Inductive load switching
- > Flexibility
- > Over-load detection
- > Strong maintenance support

OPTIGA™ Trust Family to meet your security requirements

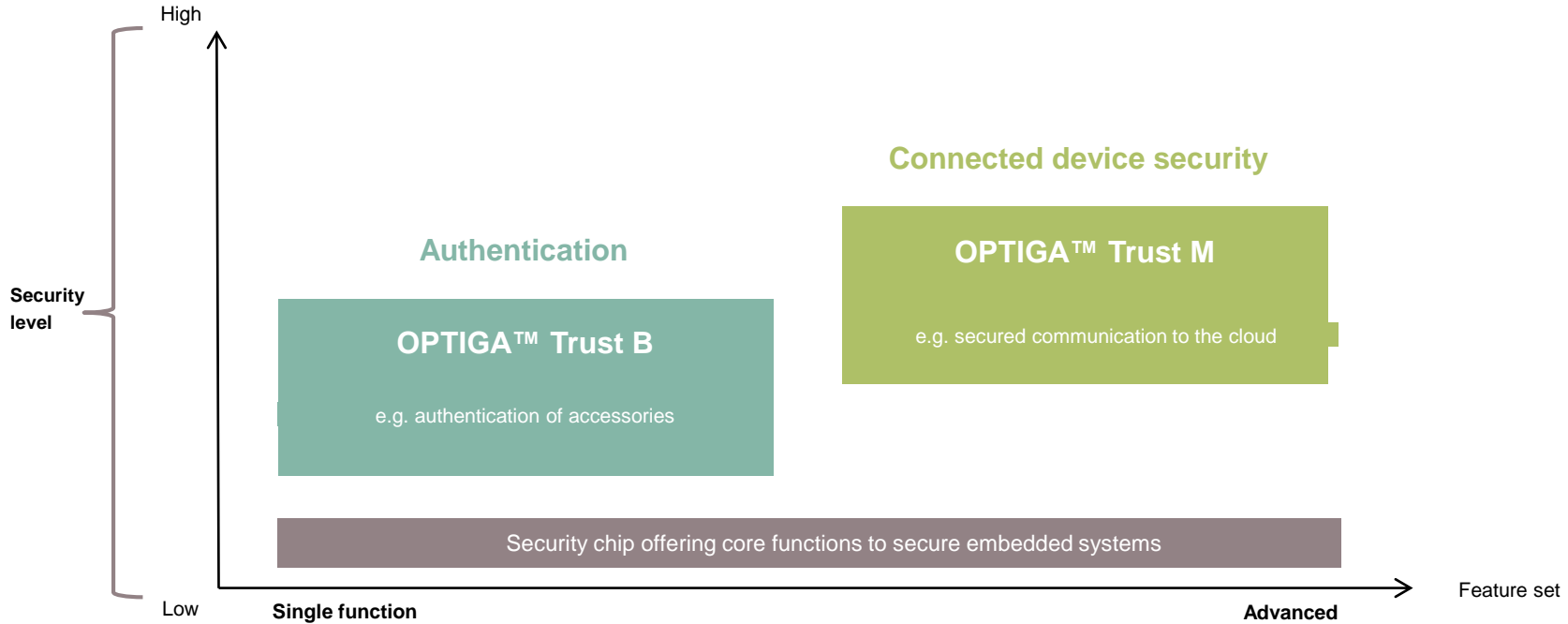

OPTIGA™ Trust M SLS32AIA

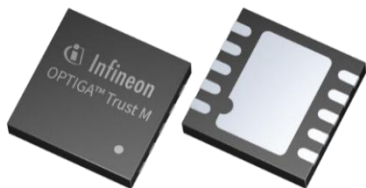

Key features

- > Based on CC EAL 6+ (high) certified security controller
- > X.509 certificate supported
- > TRNG AIS-31 certified
- > CA certificate in-field update
- > Cryptography ECC, RSA, AES, SHA
- > Extended temperature range: -40° to 105°C
- > Extended lifetime (20 years)



Exemplary schematic/topology:

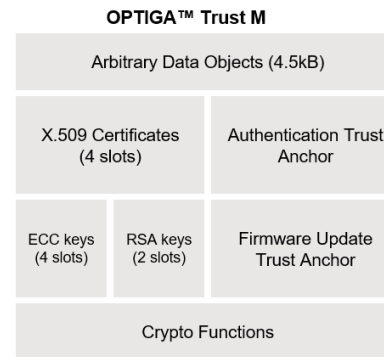

Benefits

- > **Secured zero-touch provisioning** for leading cloud providers.
- > **Easy integration** based on a range of turnkey use cases to minimize your integration efforts.
- > **Future-proof security** provided by the most advanced cryptographic schemes.
- > **Open Source** framework to benefit from direct support from developers.

OPTIGA™ Trust solutions and relevant use cases

Use Case	Description
Brand protection and authentication of accessories	OPTIGA™ Trust B can be used in accessories/consumables to verify that genuine parts are used.
Mutual authentication	OPTIGA™ Trust M can secure multiple secret keys and certificates. It can be used to perform mutual authentication with clouds and other systems. (e.g. a device can authenticate with commissioners, controllers, ecosystems, and other entities)
Secured communication	OPTIGA™ Trust M can be used to establish secured communication with a cloud or other service or device
Secured storage	OPTIGA™ Trust M adopts a Common Criteria EAL6+ certified hardware trust anchor which offers protection against various physical and reverse-engineering attacks. Data stored in the Trust M is protected against various extraction techniques as verified by the Common Criteria certification.
Secured firmware update	OPTIGA™ Trust M can be used to cryptographically verify and perform secured firmware updates.

XENSIV™ angle-sensors in electrification for drives



Key features

- › Wide portfolio of magnetic position sensors
- › Offering Hall, GMR, AMR and TMR sensors
- › Digital and analog interfaces for angle sensors available



Benefits

- › Suitable for all commutation types for motor control
- › ISO ready and ISO compliant versions

Broad product portfolio for all kind of electric motor commutation types

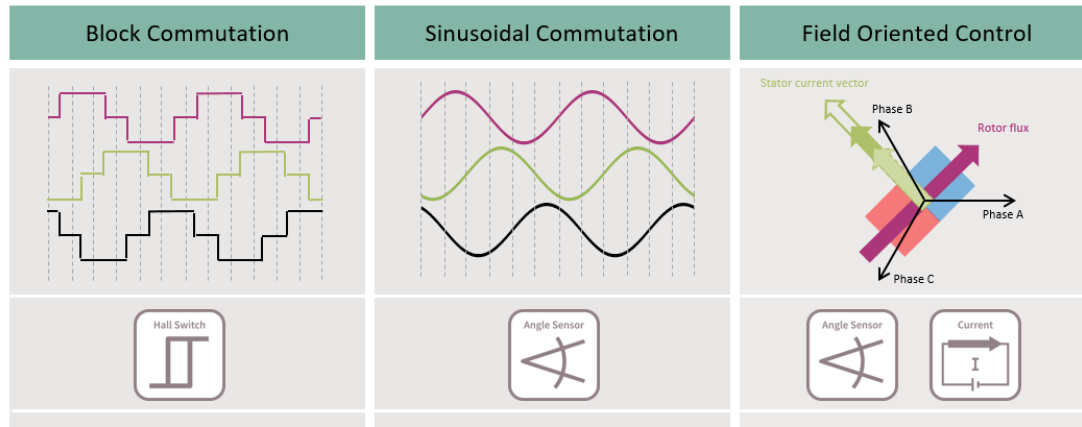

XENSIV™ enablement examples: Infineon provides supportive material for a short time-to-market



Documents



- › Datasheets
- › Product briefs
- › User manuals
- › Product presentations

Application notes

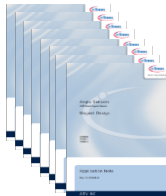

- › Joystick
- › 3D Hall for multifunction knob
- › 3D Hall for gearstick
- › 3D Hall for linear movement
- › 3D Hall for angle measurement

Online simulation tools

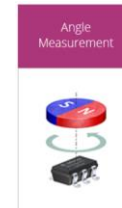

Evaluation tools & Software

- › Sensor-2-go kit for 3D Hall sensors incl. extensions
- › Sensor-2-go kit for speed sensor & current sensor
- › Shield2Go for 3D and current sensors
- › Shield2Go for barometric pressure sensors
- › Demo boards for radar

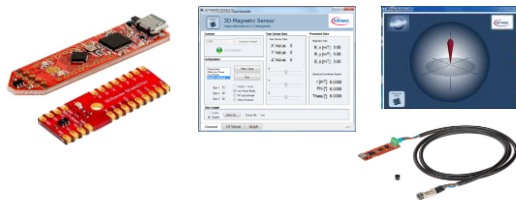

Sensing toolboxes

- › Sensing toolbox for shaft sensing (end-of-shaft, integrated end-of-shaft) available
- › Sensing toolbox for current sensing in work right now
- › Main purpose: adapt fast to dedicated application

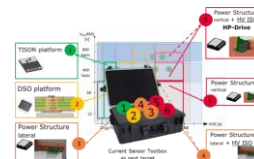

XENSIV™ TLI4971 - high precision coreless current sensor for industrial applications



Key features

- › Magnetic coreless differential sensor
- › Power package
- › Best-in-class temperature and lifetime accuracy
- › Easy system integration
- › Protection capability for upcoming IGBT technologies

Exemplary schematic/topology:

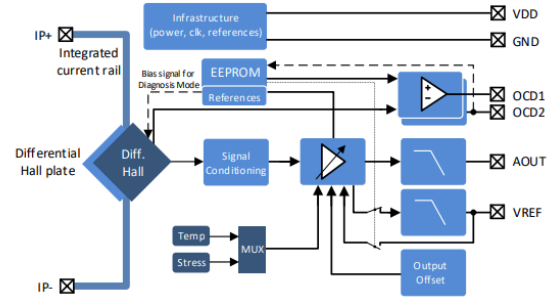

Benefits

- › No hysteresis
- › Overload capability
- › Stray field immunity
- › Very low power dissipation
- › Superior system accuracy
- › Support of ISO61508/ISO26262 requirements
- › Simplified layout, reduced design risk
- › Space and cost saving

Gate driver portfolio serving power ranges up to 200 kW and above

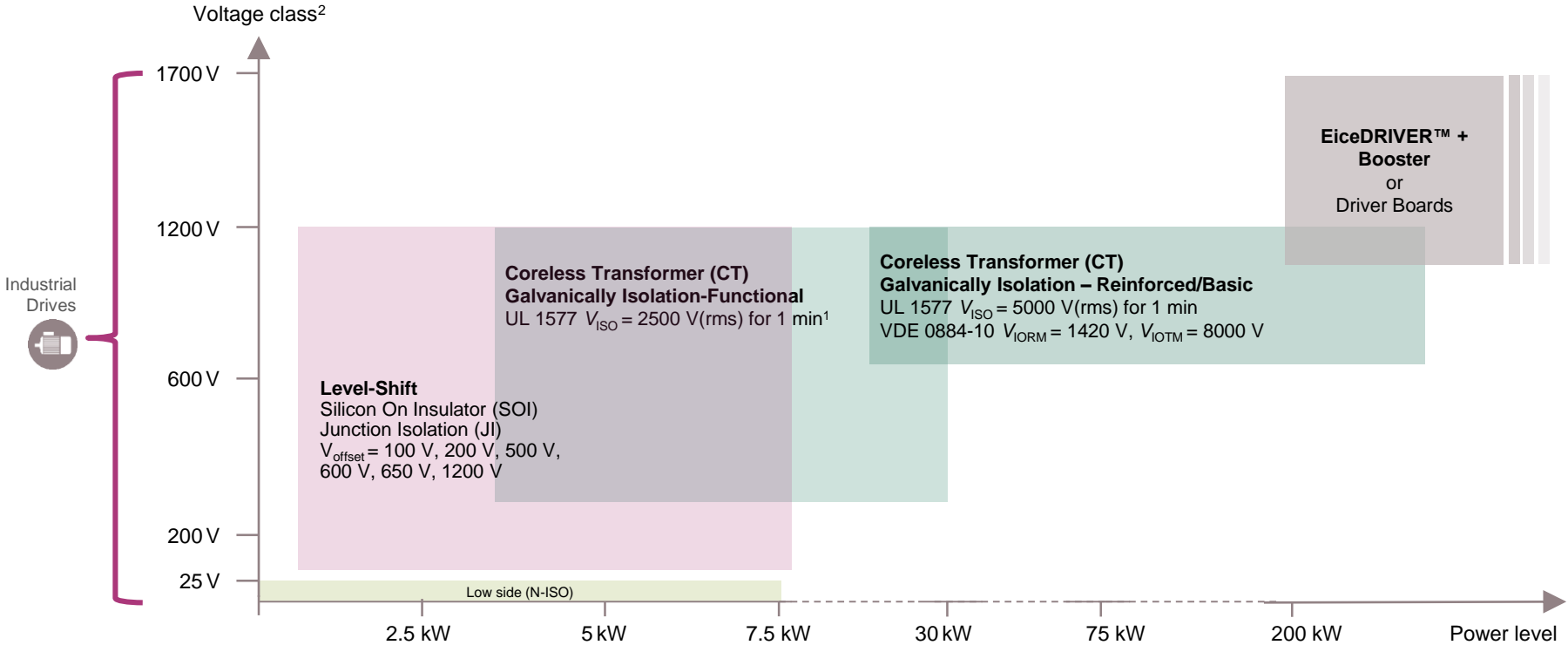

Note 1: 1EDC Compact only

Note 2: Voltage class is defined based on different driver configurations.

1. For single high-side, high- and low-side, half bridge and three phase gate drivers, voltage class is defined as switch break down voltage in applications.
2. For low side drivers, voltage class is defined as maximum operating range supply voltage.
3. For special cases as 1EDNx550 (1EDN-TDI), common mode rejection (CMR) voltage range up to 80 V.

Key gate driver categories for industrial drives

Non-Isolated GD

Low Voltage

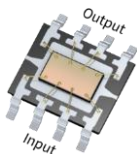

- › **Comprehensive Families** of single- and dual-low-side drivers with flexible options for output current, logic configurations, and UVLOs
- › **Rugged technology** of the high-voltage gate drivers, and on the latest state-of-the-art 130-nm process
- › **Industry-standard** DSO-8 and small form-factor SOT23 and WSON packages

Level-Shift GD

Junction Isolation (JI) & Silicon on Insulator (SOI)

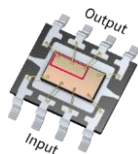

- › **Proven JI technology** trustfully used in all high-voltage gate drive applications for 20 years
- › **Infineon SOI technology** with integrated boot-strap diode, lower level-shift losses, and industry **best-in-class robustness** against – VS transient spikes
- › **Largest portfolio** of 200 V, 600 V, 700 V and 1200 V industry-standard gate drivers

Isolated GD

Coreless Transformer

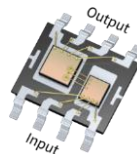

- › **Magnetically-coupled isolation technology** provides galvanic isolation for industrial applications
- › **Strongest gate-drive output currents** (up to 10 A) reducing need for external booster circuits
- › **Reliable and accurate protection** options of precise & tight desat protection, active Miller clamp, isolation rating in different packages

Solid-State Relay

Optical Safety Isolation

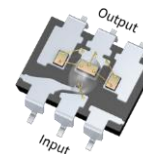

- › **Optically isolated technology** provides galvanic isolation for safety applications
- › **Established** and reliable products with over 20 years of history
- › **Wide range of applications** from industrial automation to test and measurement equipment

EiceDRIVER™ Compact (including X3 Compact 1ED31xx)

Single-channel isolated gate driver with active Miller clamp or separate output



Key features



- > Single channel isolated gate driver with **up to 14 A** (no booster required)
- > **Active Miller Clamp or Separate outputs**
- > **40 V absolute maximum** output supply voltage,
- > Exceptional CMTI robustness **> 200 kV/μs**
- > **90 ns** propagation delay with **30 ns** input filter, **7 ns** propagation delay matching
- > Suitable for fast switching application
- > **DSO-8 150 mil (4mm creepage) & 300 mil wide-body package (8 mm creepage)**
- > For high voltage IGBT, MOSFET, CoolSiC™ SiC MOSFET
- > Isolation capabilities & certification
- 1ED31xxMU12H: **UL 1577 certified** $V_{ISO}=5.7$ kV(rms)
- 1ED31xxMC12H: **UL 1577 & VDE 0884-11**, release in **2021 Q1**
- > **Evaluation board available:**
- > EVAL-1EDC20H12AH-SiC; EVAL-1EDI60H12AF
- > EVAL-1ED3121MX12H; EVAL-1ED3122MX12H; EVAL-1ED3124MX12H



Exemplary schematic/topology:

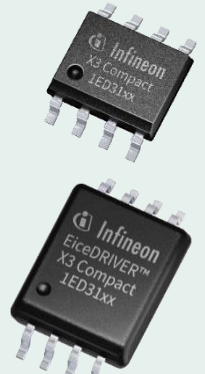
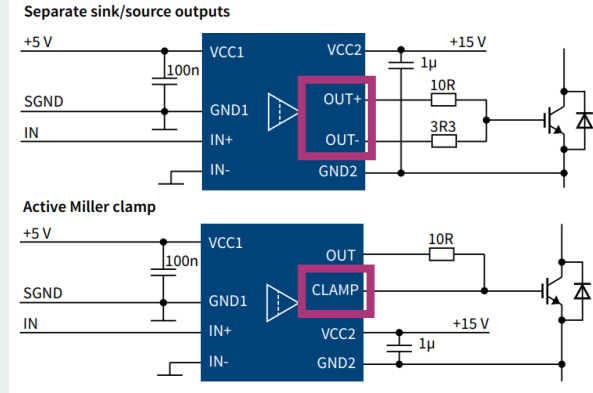

150 mil	1ED3124MU12F	1EDI60N12AF	1ED3125MU12F	1EDI30I12MF
300 mil	1ED3123MU12H	1EDI60H12AH		1EDI30I12MH
	1ED3124MU12H	1EDC60H12AH	1ED3122MU12H	1EDC30I12MH
Typ. Output current	±14 A	±10 A	±10 A	±6 A
Propagation delay	90 ns	125 ns	90 ns	300 ns
Input Filter	30 ns	40 ns	30 ns	240 ns
CMTI	200 kV/μs	100 kV/μs	200 kV/μs	100 kV/μs
Output supply voltage	40 V	40 V	40 V	20 V
Propagation delay matching	7 ns	20 ns	7 ns	20 ns
Certification				

EiceDRIVER™ Enhanced X3 analog & X3 digital – product overview

Key features

- > Single channel isolated gate driver with **3 / 6 / 9 A**
- > Active Miller clamp(clamp driver), DESAT, soft-off
- > Exceptional CMTI robustness > **200 kV/μs**
- > Thermal shutdown
- > **X3 Analog configurability**
 - Adjustable **DESAT filter time & blanking time** and **soft-off current** with external resistor
- > **X3 Digital configurability**
 - **Full adjustable via I2C bus**: 3 address configuration, 27 parameter configuration, 16 status
 - **Configurable** UVLO, **DESAT²**, TLTO, Soft-off, Miller clamp
- > Isolation capabilities & certification
 - 1ED34/38x1MU12M: **UL 1577 certified** $V_{ISO}=5.7$ kV(rms)
 - 1ED34/38x1MC12M: **UL 1577 & VDE 0884-11 (2021-Q1)**
- > **DSO-16 fine pitch, 300 mil wide-body package (8 mm creepage)**
- > For IGBTs, MOSFETs, CoolSiC™ SiC MOSFETs

Exemplary schematic/topology:

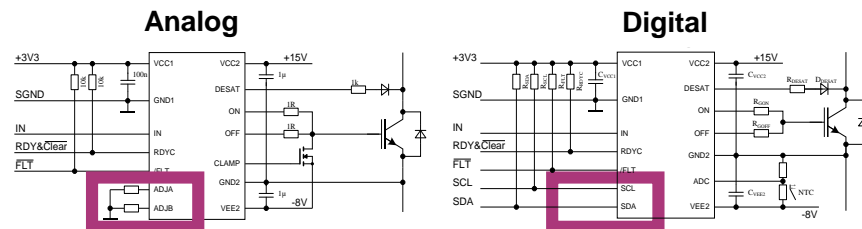

Benefits

- > X3 Analog: **Flexibility** based on **register-based configuration** adjustments
- > X3 Digital: **Highest flexibility** introduced by **register-based adjustments via I2C**
- > **Reduction in hardware complexity** with less customer product variants
- > **Reduction in the evaluation time** with adjustable parameters for **faster time-to-market**.



EiceDRIVER™ half-bridge isolated gate driver (isolated only on high side) 2ED020112-F1



Key features



- > Galvanic isolation based on coreless transformer on the high side, **half bridge** isolated gate driver IC
- > Drive up to **1200 V IGBT** and n channel power **MOSFET**
- > **Interlock** (shoot through protection)
- > Power supply operating range from **14 V** to **18 V**
- > Gate drive currents of **+1 A / -2 A**
- > Dedicated **Shutdown** input
- > Matched propagation delay for both channels (typ. 85ns propagation delay / ± 25 ns propagation delay mismatch)
- > High dV/dt immunity
- > Low power consumption
- > General purpose **operational amplifier**
- > General purpose **comparator**
- > For High Power Constant Current Power Supply

Exemplary schematic/topology:

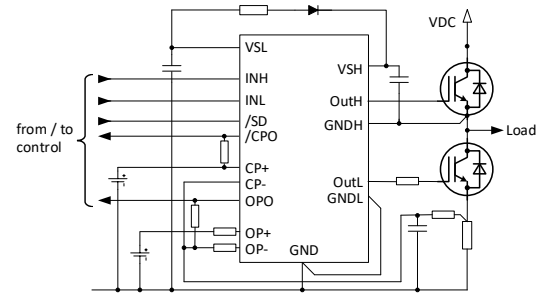

Value Proposition

- > Best **cost performance ratio** product in EiceDRIVER™ Enhanced family
- > General purpose operational amplifier and the comparator for **current measurement and OCP** reduce system cost by up to 0.15€ per half bridge
- > Reduced external components enables a simpler PCB layout, faster design-in, and improved reliability

DSO-18



ED-E
Enhanced

S25FL-L serial NOR Flash memories stores the boot code and application critical parameters even in rush environment

S25FL064L
S25FL128L
S25FL256L
Quad SPI
NOR Flash



Key features

- > Densities 64Mb to 256Mb – voltage level 3.3V (2.7V-3.6V)
- > Easy to design in due to industrial standard floating gate technology
- > 4KB Uniform Sector Size / Easy to connect to most microcontrollers
- > 100,000 Program/Sector Erase Cycles, minimum
- > 0.30-ms Program time per 256 bytes and a 50-ms Sector Erase time
- > 20 Year Data Retention, minimum
- > Temperature range up to 125°C, multiple packages

Exemplary schematic/topology:

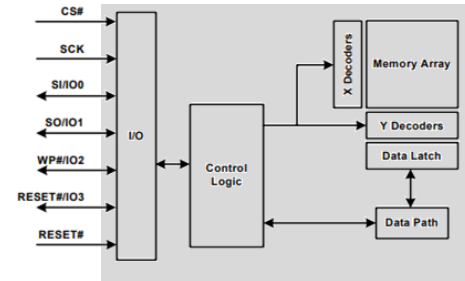

Benefits

- > Easy to use and compliant due to Industrial Standard QSPI Interface
- > Robust design with high temperature grade products
- > Available in different packages and scalable densities

Series	Density	Device	SOIC-8 208 mil	SOIC-16 300 mil	WSON 4 x 4 mm	WSON 6 x 5 mm	WSON 8 x 6 mm	BGA24 8 x 6 mm 5 x 5 Ball	BGA24 8 x 6 mm 4 x 6 Ball
FL-L	64Mb	S25FL064L	✓	✓	✓	✓		✓	✓
	128Mb	S25FL128L	✓	✓		✓		✓	✓
	256Mb	S25FL256L		✓			✓	✓	✓

SemperFlash serial NOR Flash offers most flexibility, highest performance and functional safety with densities 256 Mb to 4 Gb



S25HL-T
S25HS-T
S26HL-T
S26HS-T
S28HL-T
S28HS-T
NOR Flash

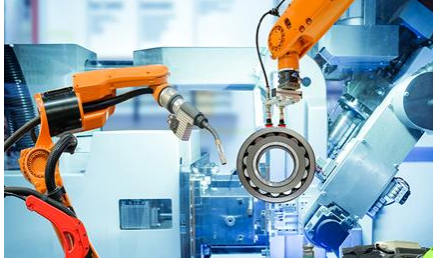

Key features

- > ASIL-B / SIL-2 Functional safety compliance on component level
- > Enhanced reliability (ECC and CRC)
- > EnduraFlex™ Architecture – integrated wear leveling to optimize endurance and data retention
- > Integrated diagnostic features for a safe and reliable operation
- > High Speed Read Bandwidth up to 400MB/s – instant on feature
- > xSPI compliant – easy to adopt to microcontroller (QSPI, OctalSPI, Hyperbus – perfect match to use with HyperRAM)



Exemplary schematic/topology:

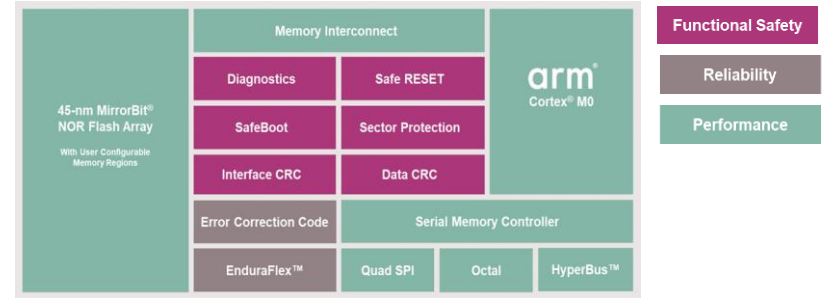

Benefits

- > Cortex M0 offers enhanced diagnose and safety features
- > High speed reading for instant on
- > EnduraFlex™ allows to partition the NOR Flash, reduced component count and increase reliability
- > Functional safety compliant reduces certification time and shorten time-to-market
- > Designed for high reliability in rough and higher temperature
- > Longevity >10 years

Broad RAM product portfolio to meet performance requirements

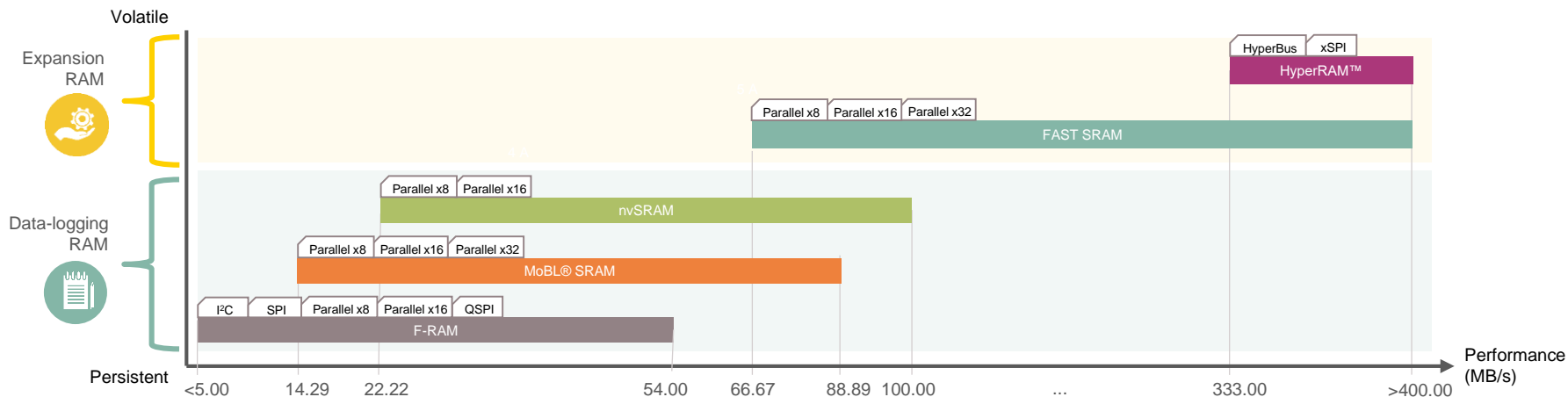

F-RAM	MoBL@ SRAM	nvSRAM	FAST SRAM	HyperRAM™
<ul style="list-style-type: none"> > 4Kbit to 16Mbit > Serial and Parallel interface > Instant non-volatility > Optimized solution for low-power data-logging 	<ul style="list-style-type: none"> > 256Kbit to 64Mbit > Access time: 45 ns – 70 ns > SER < 0.1 FIT/Mbit > Ultra-low standby currents for extending battery life 	<ul style="list-style-type: none"> > 64Kbit to 16Mbit > Access time: 20 ns – 45 ns > Unlimited endurance > Optional features including RTC, timer and alarm 	<ul style="list-style-type: none"> > 256Kbit to 32Mbit > Access time: 10 ns – 15 ns > SER < 0.1 FIT/Mbit > Optimized solution for a high-speed cache memory 	<ul style="list-style-type: none"> > 64Mbit to 128Mbit > Serial HyperBus™ & xSPI > Up to 400 MB/s speeds > Ideal solution for a high-speed serial buffer memory

Persistent RAM Solutions for Industrial Motor Drives: NVRAM

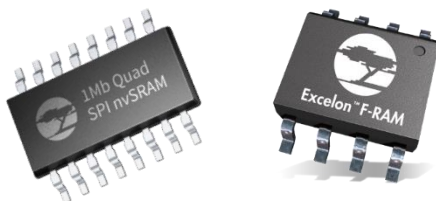

Key features

- > **nvSRAM**
 - 256Kbit to 16Mbit in density
 - Parallel asynchronous interface with access speeds ≤ 45 ns
 - Unlimited read/write cycles
 - Optional RTC, watchdog timer, and clock alarm
- > **F-RAM**
 - 4Kbit to 16Mbit in density
 - Serial interface 40/50 MHz SPI and 108 MHz QSPI
 - 10^{14} read/write cycles – virtually unlimited endurance
 - Instant non-volatility with NoDelay Write

Exemplary schematic/topology:

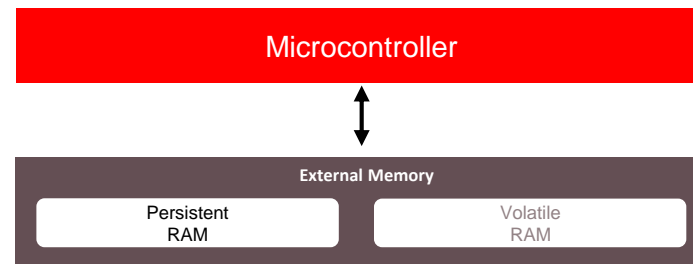

Benefits

- > Eliminate battery for power back-up from the system
- > Capture real-time, mission-critical system data at high speeds
- > Retain data instantly on power-loss or system shutdown
- > Log data continuously over a 15-year product lifespan
- > Enhance system reliability with on-chip ECC and CRC
- > Design with parallel or low-pin-count serial SPI and QSPI interface
- > Support wide operating voltages and temperature grades

Additionally, F-RAM technology is immune to data corruption due to magnetic fields and radiation exposure

Persistent RAM Solutions for Industrial Motor Drives: MoBL[®] SRAM

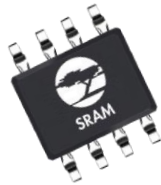

Exemplary schematic/topology:

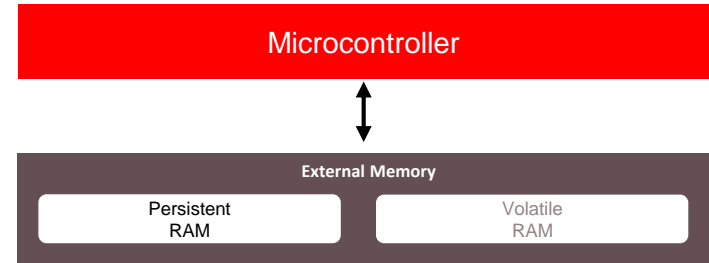

Key features

- › **MoBL[®] SRAM with ECC**
 - 4Mbit to 64Mbit in density
 - Access times: 45 ns – 55 ns
 - Parallel asynchronous interface
 - Bus-width configurations: x8, x16 and x32
 - Standby current (at 85°C) of 6.5 µA for 8Mbit, 8.0 µA for 16Mbit
 - Wide operating voltage range: 1.8V - 5.0V
 - High reliability with on-chip ECC
 - Industrial and Automotive temperature grades



Benefits

- › Capture real-time, mission-critical system data at high speeds
- › Extend system battery life with best-in-class standby currents
- › Log data continuously over a 15-year product lifespan
- › Realize reliable systems with soft-error rates (SER) < 0.1 FIT/Mbit
- › Support wide operating voltages and temperature grades
- › Design with asynchronous interface compatible with 32-bit MCUs

Volatile RAM Solutions for Industrial Motor Drives: FAST SRAM



Key features

- > **FAST Asynchronous SRAM with ECC**
 - 2Mbit to 16Mbit in density
 - Fast access times: 10 ns – 15 ns
 - Parallel asynchronous interface
 - Bus-width configurations: x8, x16 and x32
 - Wide operating voltage range: 1.8V - 5.0V
 - High reliability with on-chip ECC
 - Industrial and Automotive temperature grades

Exemplary schematic/topology:

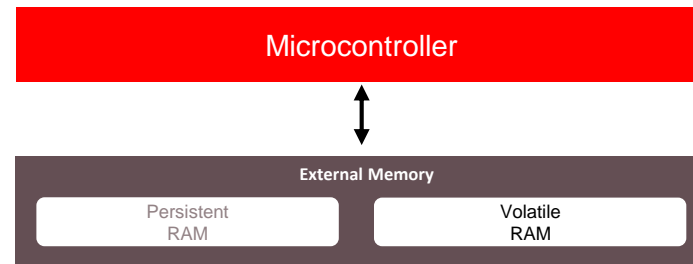

Benefits

- > Achieve data throughput up to 3.2Gb/s with a fast, expansion RAM
- > Ideal for systems requiring high-speed expansion RAMs for use as a scratch-pad memory to execute control algorithms
- > Realize reliable systems with soft-error rates (SER) < 0.1 FIT/Mbit
- > Support wide operating voltages and temperature grades
- > Design with asynchronous interface compatible with 32-bit MCUs

FAST asynchronous SRAMs with on-chip ECC have an optional PowerSnooze™ feature with a Deep-Sleep mode to save on idle currents ($I_{DS} = 15\mu A$) while operating at 10 ns access time.

Volatile RAM Solutions for Industrial HMI Systems: HyperRAM™



Key features

- > **HyperRAM™**
 - 64 Mbit to 128 Mbit in density
 - 200 MHz DDR, JEDEC-compliant (JESD251A) HyperBus™ and xSPI interface
 - Operating voltage support of 1.8 V and 3.0 V
 - High reliability with automotive AEC Q100 qualification
 - Industrial and Automotive temperature grades (up to 105 °C)
 - Provides Hybrid Sleep Mode, Deep Power Down Mode and Partial Memory Array Refresh to minimize power consumption



Exemplary schematic/topology:

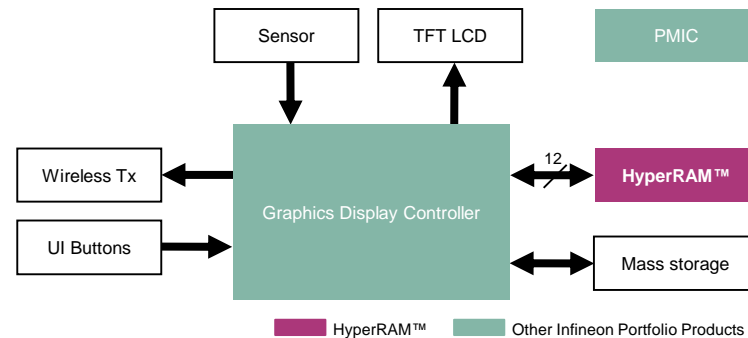

Benefits

- > Achieve data throughput up to 3.2 Gb/s
- > Ideal for systems requiring high-speed expansion RAMs for use as a display buffer for smooth graphics rendering
- > Access both the HyperFlash™ and HyperRAM™ with only 11 control pins
- > Support wide operating voltages and temperature grades
- > Leverage HyperBus™ [ecosystem](#) to access IP for leading platforms

Modular Application Design Kit (MADK)

CoolSiC™ MOSFET evaluation board for industrial drives

Compact and flexible 3-phase motor drive evaluation platform

- › CoolSiC™ MOSFET in EasyPACK™ 1B can easily tested

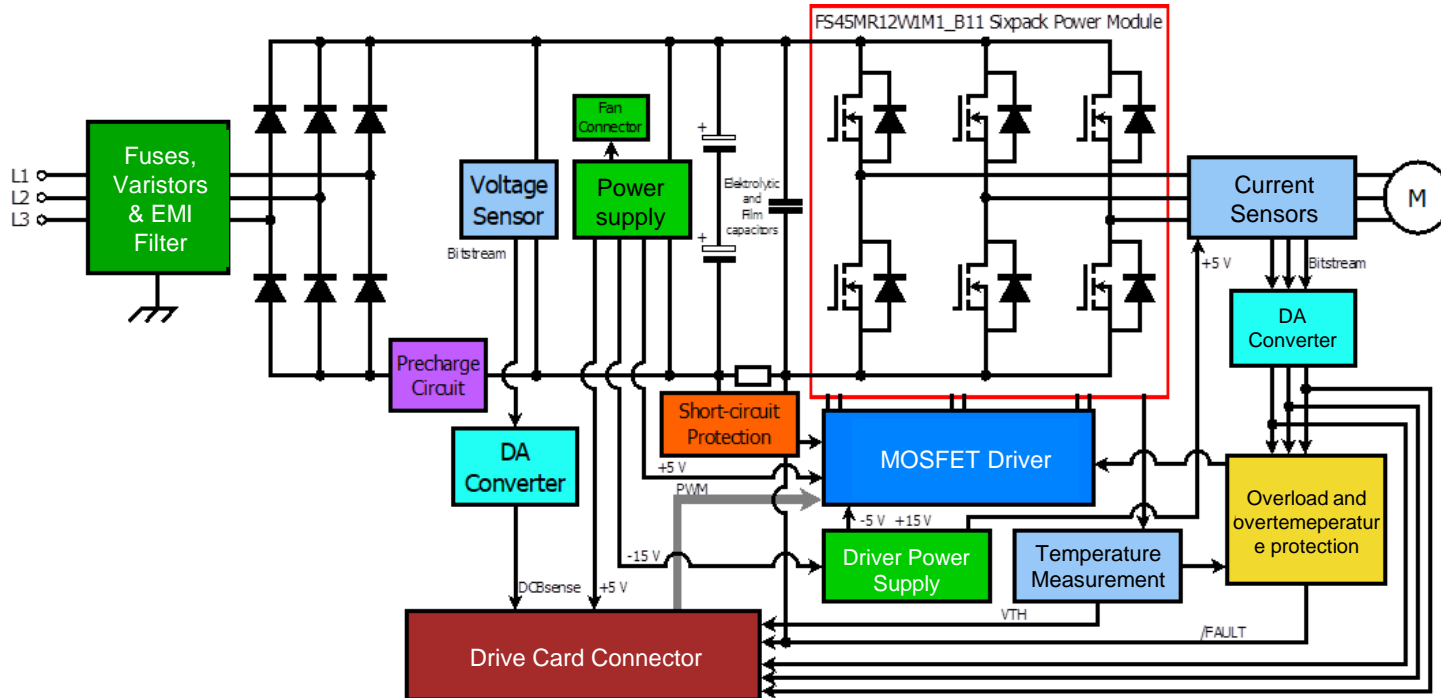

Modular Application Design Kit (MADK)

CoolSiC™ MOSFET evaluation board for industrial drives



Parameters	Values	Conditions / Comments
Including FS45MR12W1M1_B11 & 1EDI20H12AH		
Input		
Voltage	340 – 480 V _{rms}	
Current	16 A _{rms}	Input 400 V _{AC} , T _a = 25 °C
DC bus voltage		
	530 V – 670 V typ.	
Switching frequency		
	18 kHz nom 100 kHz max	
Output		
3ph P _{out} with mains line choke	11 kW max	Input 400 V _{AC} , f _{sw} = 18 kHz, T _a = 25 °C, T _h = 70 °C, forced convection cooling
3ph P _{out} without mains line choke	6 kW	Input 400 V _{AC} , f _{sw} = 18 kHz, T _a = 25 °C, T _h = 70 °C, forced convection cooling, limited by input current
Current per leg at f _{sw_nom}	16 A _{rms}	Input 400 V _{AC} , f _{sw} = 18 kHz, T _a = 25 °C, T _h = 70 °C, forced convection cooling
Current per leg at f _{sw_max}	8 A _{rms}	Input 400 V _{AC} , f _{sw} = 100 kHz, T _a = 25 °C, T _h = 70 °C, forced convection cooling

- > 3ph AC-connector, EMI filter, bridge rectifier, inrush current limiter, 3ph voltage source inverter and a 3ph output for connecting the motor
- > Isolated current, voltage sensing unit using $\Delta\Sigma$ -ADC (digital/analogue output)
- > Temperature sensing circuitry
- > Auxiliary power supply

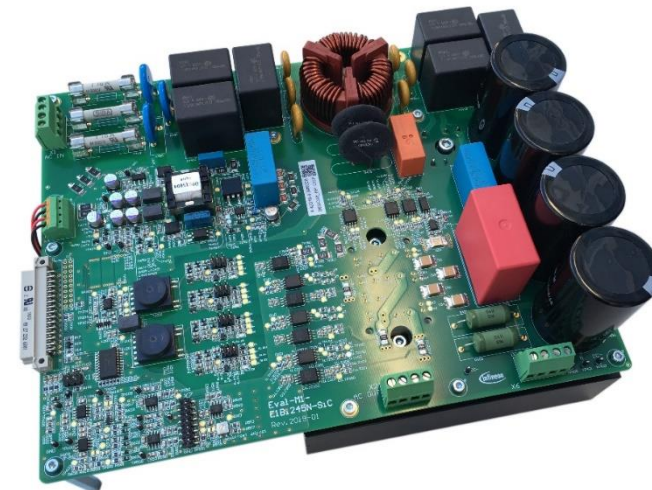

[Link to product page](#)

Agenda

- 1 Introduction
- 2 A closer look on inverter solutions
- 3 Product solutions overview
- 4 **Benefits with Silicon Carbide solutions (SiC)**
- 5 IGBT7 technology – features and benefits
- 6 Key take-aways
- 7 Further information and links

Benefits with SiC solutions for industrial drives



Increased performance

- > Reduction of power losses lead to higher performance
- > 60% reduction @ 8 kHz compared to IGBT-based

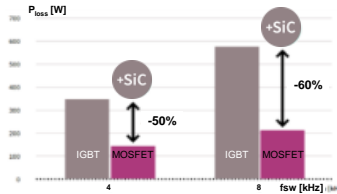

Higher robustness

- > 10 K lower operating temperature of heatsink
- > Cooling efforts significantly reduced

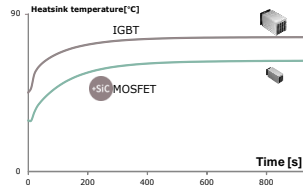

Higher power density & lower system cost

- > Heatsink can be reduced by 2/3 compared to IGBT
- > Leads to a much higher system power density

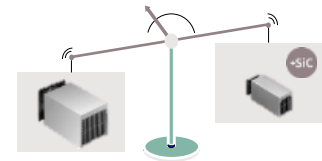

Note: Measurements based on drive demonstrator (22 kW; 50 Hz output freq.; dv/dt <5 kV/μs; IGBT system under same conditions)

CoolSiC™ MOSFET powers the next generation of servo drives design



Advantages of SiC

- › Up to 80% of total loss reduction is enabled by more than 50% switching loss reduction
- › 80% reduction of low current conduction loss by resistive behavior
- › CoolSiC™ enables motor and drive integration and hence, reduces the complexity of cabling

CoolSiC™ MOSFET

- › Enables new levels of power density and performance
- › Highest thermal conductivity
- › Simpler topologies possible
- › Smaller device footprint



No more need for a cooling fan since passive cooling is sufficient, therefore reducing your maintenance effort to a minimum.



Agenda

- 1 Introduction
- 2 A closer look on inverter solutions
- 3 Product solutions overview
- 4 Benefits with Silicon Carbide solutions (SiC)
- 5 IGBT7 technology – features and benefits
- 6 Key take-aways
- 7 Further information and links

Features and benefits of TRENCHSTOP™ IGBT7

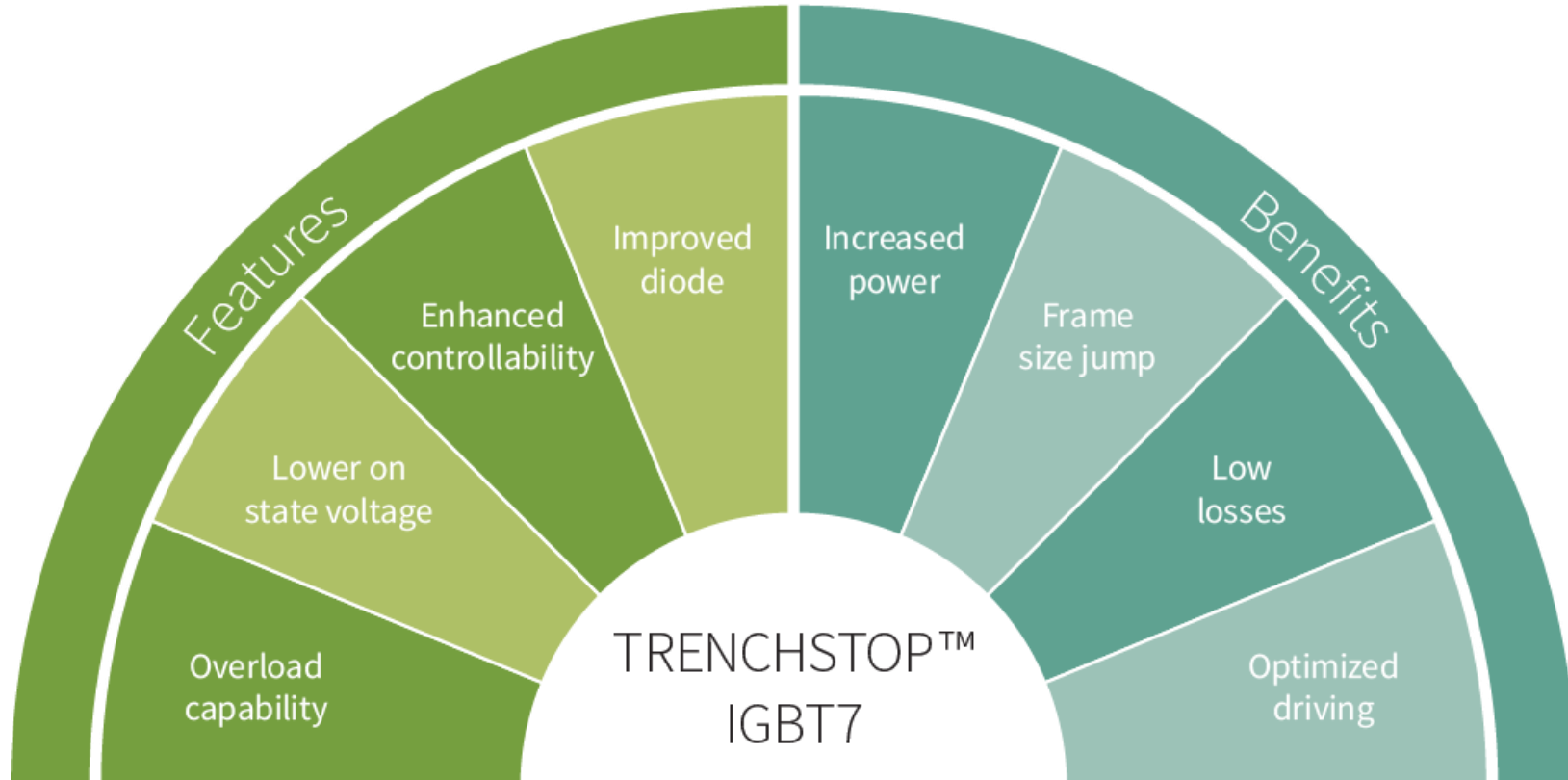

Technical features of TRENCHSTOP™ IGBT7

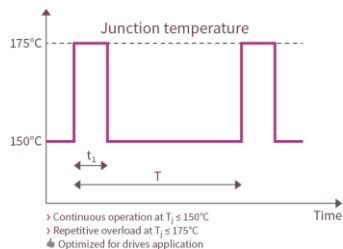

Overload capability

TRENCHSTOP™ IGBT7 allows a maximum junction temperature of 175°C whereas TRENCHSTOP™ IGBT4 is limited to 150°C . It is beneficial for drives application due to the need of repetitive short overload operation.



On state voltage

Compared to TRENCHSTOP™ IGBT4, IGBT7 lowers on-state voltage by around 20%. This brings a significant reduction in losses to target applications, especially to industrial drives, which usually operate with moderate switching frequencies.

Controllability

The TRENCHSTOP™ IGBT7 offers a high level of controllability to match the motor insulation requirements or EMI limitations. The controllability corresponds to the device's ability to vary the dv/dt by adjusting the value of the gate resistor (RG).

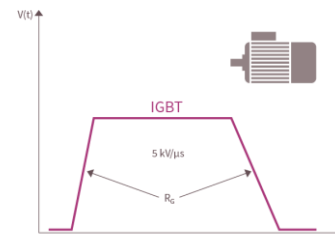

Improved diode

The EC7 emitter-controlled diode reduces the forward voltage by 100 mV relative to the previous generation EC4. This also lowers the reverse recovery losses. In addition, it improves softness, which benefits the inverter's EMI behavior.

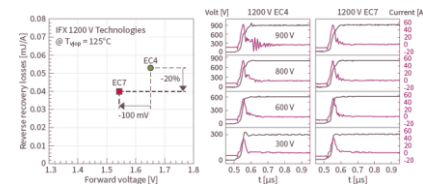

Technical benefits of TRENCHSTOP™ IGBT7

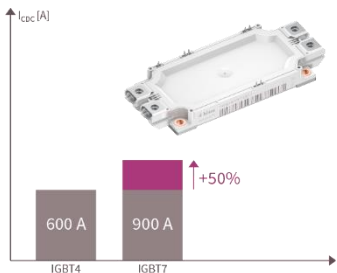

Increased power

The EconoDUAL™ 3 with TRENCHSTOP™ IGBT7 can reach up to 900 A. Benefit from higher inverter output current for the same frame size, reduced system cost by avoiding paralleling of modules.

Frame size jump

An application example for general-purpose drives (GPD) compares modules built with IGBT4 and IGBT7 technologies. This illustrates how power density can be increased while lowering system cost.

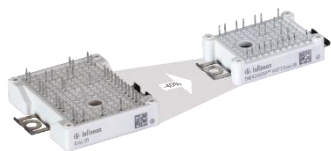

Low losses

The conduction losses at the given dv/dt limitation are significantly decreased. Moreover, there is a reduction in diode losses which leads to overall 15% lower power losses.

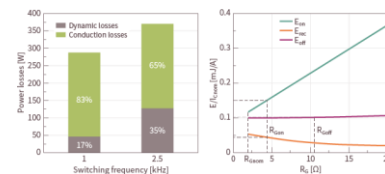

Optimized driving

CGE and CGC are balanced to give the IGBT7 full control over the dv/dt , and to optimize the switching waveform. CGE is designed to avoid parasitic turn-on effects, zero voltage supply for turn-off is feasible (unipolar gate driver power supply).

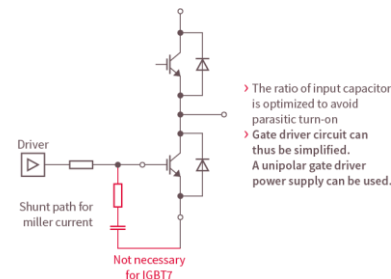

Customer benefits of IGBT7 solutions



Plug and play

- › Pin to pin compatibility with IGBT4 module
- › Lower losses
- › Higher robustness

Package Jump

- › Cost saving on module side
- › Compact inverter design
- › Higher flexibility on inverter frame size

Reduction of heatsink

- › System cost saving
- › Compact inverter design

Broad portfolio

- › Will be available in a broad power range
- › High volume production

Agenda

- 1 Introduction
- 2 A closer look on inverter solutions
- 3 Product solutions overview
- 4 Benefits with Silicon Carbide solutions (SiC)
- 5 IGBT7 technology – features and benefits
- 6 **Key take-aways**
- 7 Further information and links

Key take-aways

A grayscale background image of industrial machinery, including a large motor and various pipes and components, typical of a factory or manufacturing plant.

Infineon offers optimized technologies

- › IGBT7 perfectly matched to the needs of drives applications like overload and switching speed control
- › SiC-MOSFETs enabling a high degree of integration due to low losses

Infineon has a unique one shop offering for industrial drives

- › The right fit package for the inverter in power range from W with IPM's and 100's of kW with EconoDUAL™
- › Gate Driver solutions with enhanced functionalities
- › Current sense solutions
- › Peripherals like industrial interface IC's, security solutions and microcontrollers

Infineon is the right partner for customized solution and high volume products

- › With outstanding quality standards and production capability

Agenda

- 1 Introduction
- 2 A closer look on inverter solutions
- 3 Product solutions overview
- 4 Benefits with Silicon Carbide solutions (SiC)
- 5 IGBT7 technology – features and benefits
- 6 Key take-aways
- 7 Further information and links

Useful information material and tools

Product page links

- › [CIPOS™ IPM](#)
- › [iMOTION™](#)
- › [CoolSiC MOSFETs](#)
- › [TRENCHSTOP™ IGBT7](#)
- › [Easy power modules](#)
- › [EconoPIM™ 2 & 3](#)
- › [EconoDUAL™ IGBT modules](#)
- › [EconoPACK™ 4](#)
- › [PrimePACK™ IGBT modules](#)
- › [32-bit XMC™ microcontroller](#)
- › [ISOFACE™ digital input ICs](#)
- › [OPTIGA™ security solutions](#)
- › [Magnetic sensors](#)
- › [Current sensor](#)
- › [EiceDRIVER™ gate driver](#)
- › [External memory](#)
- › [Wireless connectivity](#)

Application pages

- › [Overview](#)
- › [Induction motor](#)
- › [Permanent magnet synchronized motor](#)
- › [Servo motor](#)
- › [Motor control for industrial automation](#)
- › [Robotics](#)

MADK

- › [iMOTION™ Modular Application Design Kit MADK](#)

Online simulations

- › [IPOSIM](#)
- › [Discrete IGBT Motor Drive Simulator](#)
- › [IPM 3-phase Inverter Simulator](#)

Online forums

- › [Silicon Carbide forum](#)
- › [IGBT modules forum](#)
- › [IGBT discretes forum](#)



Part of your life. Part of tomorrow.