



Pushing Performance



People | Power | Partnership

Single Pair Ethernet

The Infrastructure for IIoT

Single Pair Ethernet

The Infrastructure for IIoT.



Pushing Performance

People | Power | Partnership

Table of Contents

<i>Introduction</i> _____	2
<i>Mega trends in information and communications technology (ICT) and their effects</i> ____	2
<i>Standards activities for single pair transmission channels and components</i> _____	4
<i>Products for single pair balanced transmission channels</i> _____	6
<i>Conclusion and outlook</i> _____	7
<i>Final thoughts</i> _____	8
<i>Terminology</i> _____	8

Single Pair Ethernet

The Infrastructure for IIoT.



Pushing Performance

People | Power | Partnership

Introduction

Ethernet is the leading network protocol in LAN applications and is increasingly gaining ground in new areas. At the start of the Ethernet “era” in the early 1980s, coaxial cabling dominated (called thick Ethernet–yellow cable, thin or cheap Ethernet). In the 1990s, the focus shifted to cabling solutions based on symmetric cabling (twisted pair) and fiber optics.

Initially, twisted-pair cabling relied on two-pair cables. This used a wire pair as a transmission and reception line (100Base-TX). This principle, limited to a transfer rate of 100Mbit/s, is still the primary transfer principle in industry and automation systems technology today and is often achieved using star-quad cable designs. To achieve higher transfer rates of 1 Gbit/s and 10 Gbit/s, a transfer technique was selected that uses four symmetric pairs in connection with 8-pole plug connectors.

Now, let’s discuss the transfer of Ethernet with a single strand pair, a solution that runs contrary to the technical development of Ethernet and its associated cabling.

This white paper deals with the background of these developments, with the technical details and the normative activities and the applications for single pair Ethernet.

We consider the performance of new chipsets and discuss the classification of single pair cabling regarding existing two and four-pair versions and future cabling.

Mega trends in information and communications technology (ICT) and their effects

The development of new communication technologies and their associated cabling philosophies are influenced and driven by the current ICT mega trends, such as IoT, Industry 4.0 (I4.0), cloud computing and smart technologies. This leads to new demand profiles regarding communications technology and the network infrastructure behind it, based on cables and connectors.



Figure 1 - The mega trend IoT

Demands for this new technology include: high availability, quick access (incl. to distributed data) and fast transport of this data from A to B. Secure transfer of large datasets in different application areas up to determinism (real-time transfer, i.e. guaranteed data transfer within a defined time frame) is also critical.

Data transfer should remain cost efficient. For devices, cables and connecting hardware this means they must achieve higher performance, be smaller and stronger as well as possess a high degree of modularity and compatibility (exchangeability and plug-compatibility). These demands can only be fulfilled through innovation, i.e. game-changing technology developments of products with consistent international standardization.

HARTING Americas

1370 Bowes Rd
Elgin, IL 60123
TechSupportUS@HARTING.com

5.21.2020

Version 1.1 - Page 2 of 9

Single Pair Ethernet

The Infrastructure for IIoT.



Pushing Performance

People | Power | Partnership

Internet of Things (IoT):

The term IoT describes the coming “technological intelligence” of things such as computers, technological facilities up to “things”/objects. This requires unique identification of physical objects through system designations (MAC address, RFID, labeling etc.), which allows linking of these physical objects with a virtual representation (description/representation/admin shell etc.).

Additional requirements include the ability of these objects to communicate with each other (exchange data), the development of technologies suitable for this and the constant miniaturization of technical objects and their communication facilities.

The visionary goal of IoT is to achieve artificial intelligence, that is enabling devices to make decisions. This should occur independently of people using algorithms or special software.

Industry 4.0 - I4.0:

I4.0 takes the same approach as IoT, but focuses strongly on processes for the industrial production of products. In this way, I4.0 is pushing the development of all known automation technology whilst creating novel forms of secure information exchange and networking. Highly developed sensor/actuator technology is crucial for I4.0. Therefore, I4.0 represents a certain sub-set of IoT but cannot be considered equal to IoT. I4.0 takes industrial production, from folding boxes to highly complex products such as cars, to a new level, it forges new increases in efficiency and allows individual products (custom products, niche products) to enjoy the advantages of mass production.

I4.0 will introduce long-term changes to our professional world and expand the demand profile of many users in production.

Cloud Computing:

Cloud computing describes the provision of IT services (storage space, user software, database access or computation power) via the Internet. Physically, data centers provide these services, which are often linked virtually with each other (cloud).

Cloud computing is not only of existential importance for companies. Private users also make use of applications such as Google or social networks, cloud computing. IoT and I4.0 also rely on the cloud computing.

Smart Technologies:

The term smart technologies describes technologies, devices or procedures that use “clever” solutions. Classic examples include intuitive user interfaces on tablets or smart phones, but also the collection of weather information from sensors, from different manufacturers that are distributed worldwide. This means that smart technologies can be compared with trends, such as increasingly integrated “intelligence”, miniaturization, simplification and networking.

IoT, I4.0 and cloud computing make use of smart technologies.

Another trend in network technology and cabling is the increasing use of Ethernet protocols in new application areas. This includes many automation protocols and, increasingly, sensor/actuator applications. Numerous traffic and transport platforms such as rail, tram, bus, ship and aircraft, are fitting their fleets with Ethernet.

Whilst Ethernet has been successfully employed, in particular for passenger information systems and for WLAN services for many years now in the methods of transport mentioned above, it remained more or less unused in the private car / truck market for a long time. The automobile

Single Pair Ethernet

The Infrastructure for IIoT.



Pushing Performance

People | Power | Partnership

industry has now recognized the advantages of Ethernet and started an initiative to develop Ethernet protocols for short-distance transmission routes in vehicles.

The solution is called: single pair Ethernet for transmission distances up to 15m or 40m. This Ethernet technology has since been published in the standards of IEEE 802.3bp 1000Base-T1 (Gigabit Ethernet over single pair balanced copper cabling) and 802.3bw 100Base-T1 (100Mbit over single pair balanced copper cabling).

To achieve simultaneous transmission of data and energy, PoDL was also defined under IEEE 802.3bu (Power over Data Lines allows the transmission of both power and data over the single twisted pair. This means an additional power source is not required.).

Based on these standards, chipsets, devices, cables and connecting hardware are now being designed, developed and produced for integration in private cars.

Cabling for private cars focuses on a transmission distance of up to 15m and must be unshielded because of weight and spatial constraints.

Larger vehicles such as trucks and buses require longer transmission distances of up to 40m and, because of the associated higher EMC requirements, need to be fully shielded.

In fact, the latter single pair shielded transmission distance also has other “non-automotive” application groups and has piqued the interest of manufacturers. This is because shielded single pair Ethernet cabling offers all the features required to fulfill the mega-trend described above. They are fast, space-saving, cheap and simple to implement.

For this reason, industry is showing increasing interest in solutions with single pair Ethernet. In fact, within building automation developers are actively considering the distinct possibilities provided by integrating single pair Ethernet within the hierarchy and structure of contemporary building cabling. Then there are

also many other application areas, which present attractive opportunities for the development of single pair Ethernet.

The interest in single pair Ethernet also reflects a general trend in standardized network cabling—diversification of structured cabling for specific application areas.

ISO/IEC JTC1 SC25 WG3 includes activities or projects which deal with the realization and implementation of the technical results of IEEE 802.3 within structured building cabling.

Standards activities for single pair transmission channels and components

What do the standards activities look like for single pair Ethernet communication?

First, standardization is a continuous, dynamic process, which develops and publishes new standards, revokes existing papers or updates and launches new standards projects. Therefore, this white paper is just intended to be a snapshot of the state of standardization.

Standards activities in IEEE802.3 define the Ethernet transmission protocol and define the minimal requirements for link segments (link segments are not identical but similar to the transmission channel of cabling). ISO/IEC JTC 1/SC 25/WG 3 defines the required cabling and, in doing so, relies on the component standards for cables and plug connectors, which are given in the IEC standards groups.

In a similar way it works in TIA TR-42 where cabling standards developed specifically for the USA, Canada and Mexico. TIA is much interested to keep their own standards in line with ISO/IEC ones - mostly. As already mentioned, the following IEEE 802.3 standards have already been published.

HARTING Americas

1370 Bowes Rd Elgin, IL 60123

TechSupportUS@HARTING.com

5.21.2020

Version 1.1 - Page 4 of 9

Single Pair Ethernet

The Infrastructure for IIoT.



Pushing Performance

People | Power | Partnership

IEEE 802.3bp 1000 BASE-T1 “Physical Layer Specifications and Management Parameters for 1 Gb/s Operation over a single Twisted Pair Copper Cable”:

In this, single pair Ethernet transmission via a 15m UTP channel (Type A, unshielded) and a 40m STP channel (Type B, shielded) is defined. Both channels are specified for a bandwidth of 600 MHz, may contain up to four connections and guarantee a transmission capacity of 1Gbit/s.

IEEE 802.3bu “Physical Layer and Management Parameters for Power over Data Lines (PoDL) of Single Balanced Twisted-Pair Ethernet.”

Analogously to PoE (Power over Ethernet), this also specifies the parallel provision of energy up to 50 W via single pair Ethernet channels.

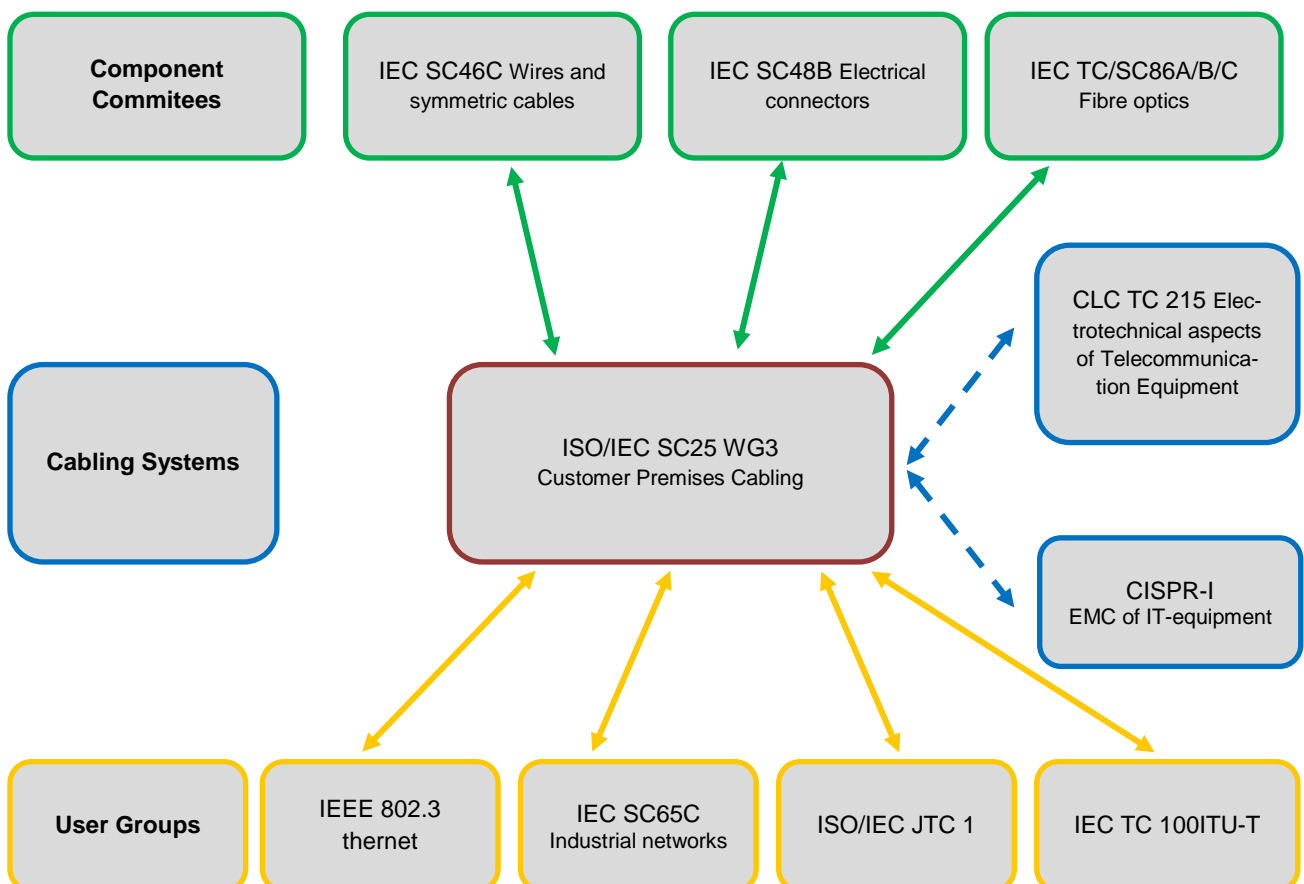

Figure 2 - Coaction of standardisation bodies for cabling

Single Pair Ethernet

The Infrastructure for IIoT.



Pushing Performance

People | Power | Partnership

Therefore, a technical report was prepared under the title "ISO/IEC11801 TR 9906" „One Pair Channels up to600MHz", which describes shielded single pair transmission channels. The target applications are "non-automotive" segments or Industry 4.0, IIoT and smart lighting in the style of IEEE 802.3bp. These transmission channels allow bidirectional transfer of 1Gbit/s by using a balanced pair up to 40 m with simultaneous energy supply of end devices.

The transmission channels typically consist of a 36m permanent link which incorporates up to four connections and two 2m long patch cords.

Standardisation design Information system Application neutral communications cable system		
European standards series:	International standards series:	Description:
EN 50173-1	ISO/IEC 11801-1	General requirements
EN 50173-2	ISO/IEC 11801-2	Office cabling
EN 50173-3	ISO/IEC 11801-3	Industrial cabling
EN 50173-4	ISO/IEC 11801-4	Residential
EN 50173-5	ISO/IEC 11801-5	Data centers
EN 50173-6	ISO/IEC 11801-6	Distributed building services

Figure 3 - Cabling design standards on European and International level scheduled for 2018/19

As part of the restructuring and updating of ISO/IEC 11801 standards series (as 3rd edition) it will also be determined in which application-specific parts an addition with single pair shielded balanced cabling is technically and economically feasible.

Initial consideration suggests this is so for ISO/IEC 11801-3 (industrial applications) and ISO/IEC 11801-6 (building automation).

The cabling specifications (see ISO/IEC 11801) allow the requirements for the components, cables and connectors to be derived. This is performed for cables in the IEC SC46C standards committee and for connectors.

in the IEC SC48B standards committee (SC = subcommittee).

IEC 61156-xx series "Cables for 1Gbs over one pair"

These international standards titles describe cables that are suitable for transferring 1 Gbit/s over a balanced pair. Application areas include office, the home and industry.

The use of 4-pair data cables should also be possible, which are capable of operating 4 single pair transmission channels. This feature is also known as so-called "cable sharing". The transmission parameters should be defined for a frequency of up to 600 MHz but has to be considered especially regarding PSNEXT of the transmission channel. This international standard should be published by 2019/2020.

IEC 63171-6 (former IEC 61076-3-125): "Connectors for electronic equipment - Product requirements - Detail specification for 2-way, free and fixed connectors for data transmission up to 600MHz with current carrying capacity"

Following the application areas and performance of the single pair cables, the two-pole connectors are being standardized up to min. 600 MHz. Standardization of the connector means that the mated interface including mechanical locking mechanism will be fully defined. Definition of the interface ensures plug compatibility and guarantees that products from different manufacturers can be used. It is expected that various designs of single pair connectors will then be available in safety class IP20 to IP65/67.

Products for single pair balanced transmission channels

The theoretical basis for designing a 40 m channel with single pair cabling have already been worked out. This means that the interested manufacturers of electronics and cabling have all the necessary information on the development and design of chipsets, cables and connectors at their disposal.

HARTING Americas

1370 Bowes Rd Elgin, IL 60123
TechSupportUS@HARTING.com

5.21.2020

Version 1.1 - Page 6 of 9

Single Pair Ethernet

The Infrastructure for IIoT.



Pushing Performance

People | Power | Partnership

The first chipsets are already available on the market. However, a range of new products, which offer optimal support for the individual applications, are still expected. Devices fitted with “single pair Ethernet” are expected within one to two years. There are basically two ways to transmit Ethernet according to 1000Base T1 over a single pair cabling channel.

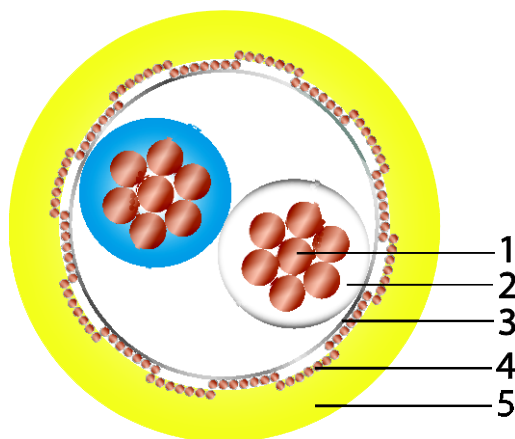

Figure 4 – Cross-section of a SPE cable

1. Conductor:	Uncoated Cu (stranded), AWG26/7
2. Isolation: Stranding element:	Cell-PP, wire ø: NW 1.25 mm Pair
3. Pair screen:	Alu-coated polyester film, metal-side external (PiMF)
4. Overall screen:	Tinned Cu-meshing, optical covering approx. 90%
5. Cable jacket:	halogen, flame-resistant compound

On the one hand, this protocol can be transferred using existing four-pair cabling according to category 7 / transmission class F (specified up to 600 MHz) or according to category 7A / transmission class FA (specified up to 1000 MHz) according to the relevant qualification and with consideration of the length restriction of 40 m. This opens up the option of “cable sharing”, which allows several single

pair Ethernet services to be transferred using a four-pair cable.

And this is the case, new single pair cable and connector products are created to serve new single pair cabling structures on the basis of single pair Ethernet.

Important points for the design of the cabling components include:

- Impedance 100 Ω, bandwidth 600 MHz and the associated fixed parameters, such as insertion loss, return loss, alien cross-talk etc.
- Complete shielding to ensure transmission quality under extreme EMC conditions
- Single pair cable with the smallest possible outer diameter (space and weight savings) for fixed and flexible installation
- Two-pole plug connectors in the smallest possible design form for use in IP20 and IP65/67 environments – mutually compatible plug interfaces.

Conclusion and outlook

The increasing network requirements driven by the demands of IIoT and IoT rely on innovative and application-specific solutions. Single pair Ethernet offers the ideal solution for cable-based communications infrastructure. Particularly for application areas in industry and building management, this represents a smart addition to the communications landscape, which combine Gigabit Ethernet performance, transmission reliability, optimal handling and remote powering as well as space and weight savings.

HARTING Americas

1370 Bowes Rd Elgin, IL 60123
TechSupportUS@HARTING.com

5.21.2020

Version 1.1 - Page 7 of 9

Single Pair Ethernet

The Infrastructure for IIoT.



Pushing Performance

People | Power | Partnership

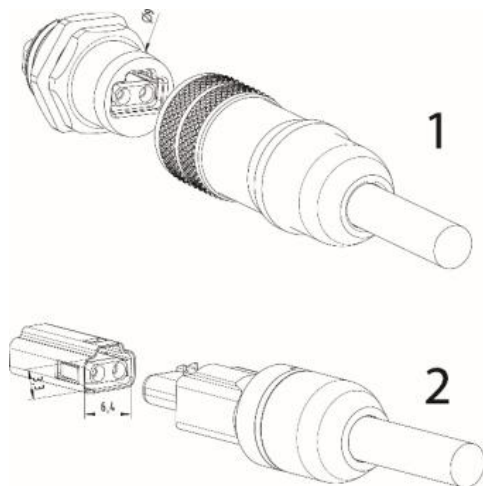

Figure 5 - IP20 and IP67 T1 connector design for SPE

Design Study IP65/67 Single Pair Ethernet Plug-Socket with PushPull Locking (1) and Design Study IP20 Single Pair Ethernet Plug-Socket(2):

- Bandwidth 600 MHz
- Fully screened design
- Transmission rate 1Gbit/s min.

The normative basics have already been defined in IEEE 802.3 Standards for applications within the automotive and non-automotive sectors. IEEE802.3 added IEC63171-6 connector standard to their documents. For the respective non-automotive applications, the planning orientation incorporated within the international standards of ISO/IEC and IEC and TIA are used. Both standardization bodies for cabling ISO/IEC SC 25 and TIA TRE-42 give an explicit statement to use connectivity according IEC 63171-6 and cables according IEC 61156-11/12/13/14 to support industrial applications. The compact design of the device connectivity and the Ethernet compatibility according to IEEE802.3 offer device development, e.g. within automation and sensor and actuator production, a networking concept that represents a simple change from bus to Ethernet technology. This allows Ethernet to penetrate further into the field

level, reduces enormously times for parameterization, initialization and programming and expands the range of functions of devices.

Single pair cabling saves space, installation time and costs. At the same time, new applications are tapped, which were previously not open for cable-based infrastructure. After the Internet and Ethernet have connected people, computers and machines both in terms of space and time, this is now also happening with objects and things. The backbone of this new technology is provided by, amongst others, single pair balanced copper cabling. With this the connection between single pair Ethernet technology and mega-trends is more prevalent within the mega-trends of IIoT and I4.0 than in cloud computing and big data.

Single pair Ethernet represents an important technological progression, but is still only an addition to existing Ethernet technologies that use multi-pair copper cables or fiber optics and will not replace them.

Final thoughts

Single pair Ethernet cabling opens up new application areas, e.g. in industry, sensor/actuator networks, smart buildings and farming and represents the future of Ethernet cabling. Therefore, single pair Ethernet particularly supports trends such as IIoT and I4.0.

Terminology

- PoE = Power over Ethernet; process with which networked devices can be supplied with power via eight-wire Ethernet cables.
- PoDL = Power over Data Line; process (analogue such as PoE) for simultaneous transfer of data and energy over a wire pair.
- SPE = Single Pair Ethernet; Ethernet transfer protocol for data transfer over a single pair symmetric copper cable.
- 1000Base-T1, also known as just "T1" = Ethernet protocol, which uses single pair cabling for transmission (IEEE 802.3 – level).

HARTING Americas

1370 Bowes Rd Elgin, IL 60123

TechSupportUS@HARTING.com

5.21.2020

Version 1.1 - Page 8 of 9

Single Pair Ethernet

The Infrastructure for IIoT.



Pushing Performance

People | Power | Partnership

Authors

Dipl. Ing. Matthias Fritsche, Product Manager Device Connectivity HARTING Electronics GmbH.

Dipl. Ing. Rainer Schmidt, Business Development Manager HARTING Electronics GmbH.

Dipl. Ing. Yvan Engels, Strategic Market Development / Standardization BU Datacom, LEONI Kerpen GmbH, Zweifaller Str. 275 – 287, 52224 Stolberg, Tel.: 0240217 359,

Matthias.fritsche@HARTING.com

Rainer.schmidt@HARTING.com

yvan.engels@leoni.com

