

APPLICATION NOTE

Bourns® PFB Transformer in Narrowband PLC Coupling Circuit Designs for Smart Energy Infrastructure



[Bourns® Model PFB Series PLC Transformers](#)



[Bourns® GMOV™ Hybrid Overvoltage Protection Components](#)

INTRODUCTION

A key enabler in the implementation of smart cities and smart homes is a new generation of advanced, intelligent energy-saving solutions and control technologies. Of particular importance in supporting this new smart energy infrastructure is a reliable, efficient and cost-effective power line transformer solution that meets the narrowband design requirements in a rapidly increasing line of telecommunication systems.

This application note will outline the change in structure of power distribution grids and present the benefits of Power Line Communication (PLC) technology for improved quality and faster service capabilities for today's smart grids. It will also provide a straightforward approach to designing galvanic isolation for a line coupling circuit using a smart meter application example. This application note also introduces Bourns® PFB Series PLC transformers that have been designed as a cost-effective solution to help designers meet narrowband requirements in the latest PLC-based systems. It also provides a recommended protection scheme that uses the Bourns® GMOV™ circuit protection component with very low capacitance to help minimize speed interference.

BENEFITS OF POWER LINE COMMUNICATION INFRASTRUCTURE

The profile of traditional power grids, which consists of centralized power distributed by long, lossy transmission lines, is changing. These older systems relied on a large generation of power from fossil fuel plants and the power generated was transferred to the customer through large networks of different power lines. As more and more renewable energy sources are added to the grid, this changes the nature of the power grid to one that is largely decentralized where consumers get their power from a local source. For example, solar photovoltaic panels give customers the freedom to generate their own electricity and sell their surplus power back to the grid.

However, adding more renewables challenges the grid operation. Wind and solar are intermittent, which means their power output can change rapidly depending on weather conditions. This sets up a potentially harmful unbalanced situation for the grid as generation must equal demand. If the system is unbalanced for too long, it could lead to a situation where a blackout occurs. Preventing disruption has led to advancements in the power grid - a more intelligent and robust system known as the 'smart grid'. One advantage of the smart grid is that it can detect a localized power outage rapidly. A prime example is with the use of new smart meters. Smart meters enable the grid operator to locate where the power outage occurred by using communication technologies such as PLC.

Current market trends highlight the need for reliable, effective, and low-cost communication technologies that can transfer vast amounts of data smoothly. A benefit of PLC communication technology is that it utilizes existing power line infrastructure to transfer information in a seamless fashion. PLC technology has also been proven to transfer large amounts of data when employed to improve the smart energy infrastructure. The good news for grid operators is that they do not have to deal with bandwidth variations as their equipment does not have to share the communication channel with other systems.

APPLICATION NOTE

Bourns® PFB Transformer in Narrowband PLC Coupling Circuit Designs for Smart Energy Infrastructure



[Bourns® Model PFB Series PLC Transformers](#)



[Bourns® GMOV™ Hybrid Overvoltage Protection Components](#)

BENEFITS OF POWER LINE COMMUNICATION INFRASTRUCTURE (Continued)

Communication methods for smart grids consist of two main groups: wireless and wired. The main advantages of wired communication are its data security, its cost-effectiveness, the extensive coverage it provides and its available infrastructure from the use of existing power lines. Wired PLC technology does not have bandwidth variation issues and PLC signals do not get obstructed by mountains or tall buildings. The main challenges for PLC technology are related to signal attenuation and noise. However, careful design considerations can minimize the disturbance these issues can cause. On the other hand, wireless is a mature technology, and can be installed rapidly but issues with cost, security, coverage area, and latency have seen a reluctance to deploy it in smart grid applications. Ultimately, wired PLC is a far more attractive option due to its low cost and high capacity.

Bourns has designed a new series of transformers tailored for Narrowband PLC (NB-PLC) technology. Designers can specify Bourns® Model PFB Series PLC transformers in the line coupling section to provide galvanic isolation and to facilitate in separating the AC mains signal and PLC signal. The series is suitable for both long distance rural and urban applications as NB-PLC technology operates at transmission frequencies less than 500 kHz. This technology also supports both indoor and outdoor communication, in the low and medium voltage range. The new Model PFBR45-ST13150S and PFBR45-SP13150S Series PLC transformers are approved and qualified with STMicroelectronics; the performance of the PLC transformers has been validated with the Company's state-of-the-art ST8500 programmable power line communication System on Chip (SoC) platform and the high-performance STLD1 differential Line Driver, both widely adopted in multiple smart grid and smart infrastructure applications worldwide. In addition, they provide a cost-effective solution that is well-suited for EMI stringent systems. These transformers also feature a small footprint, which meets the design requirements of compact applications in a broad array of PLC-based systems.

There is a plethora of different applications where power line communication technologies are needed, ranging from smart home solutions such as automation devices and CCTV cameras to smart grid applications such as smart metering and automatic meter reading for gas and water. Moreover, it has been shown that PLC-based systems can be deployed effectively for intelligent street lighting systems. For example, street lighting accounts for a large portion of the total energy consumption of a city. Adopting PLC technology in intelligent control systems offers the ability to optimize and reduce energy consumption, which is seen as a key advancement in reducing CO₂ emissions and light pollution in urban areas.

A requirement for many PLC communication-based applications such as street lighting is to implement a protection scheme that has very low leakage. An ideal solution is Bourns® GMOV™ protectors, which feature less than 1 μ A of current. The leakage may seem insignificant, but with over 1 million street lights in typical urban areas, that is equivalent to 1.2 kWh of waste if the leakage current is around 10 μ A.

APPLICATION NOTE

Bourns® PFB Transformer in Narrowband PLC Coupling Circuit Designs for Smart Energy Infrastructure



[Bourns® Model PFB Series PLC Transformers](#)



[Bourns® GMOV™ Hybrid Overvoltage Protection Components](#)

REQUIREMENTS FOR PROTECTION

Power systems and communication systems operate at two different extremes – power systems operate at very low frequencies and very high power, while communication systems operate at high frequencies and low power. PLC circuits must be well designed to handle these extremes and one key part of the PLC circuit is the line coupling circuit. The coupling circuit has two primary functions - isolation and coupling. Isolation is required to block the mains high voltage from the low voltage modem circuit, while also providing a path for the PLC communication signal to pass via the AC mains line. A simplified coupling circuit is displayed in Figure 1.

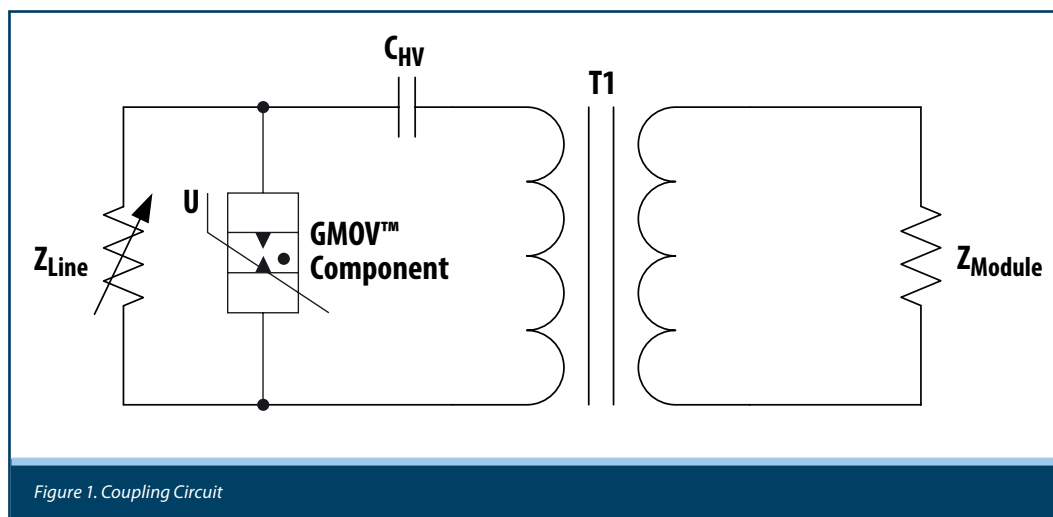

Figure 1. Coupling Circuit

For a coupling operation to the mains, a high pass filter is necessary to filter out mains voltage and its associated harmonics. To do this, a high voltage capacitor is placed before the transformer. The capacitor value can be calculated by using Equation 1 where VA_{max} is the maximum reactive power, f is the mains frequency and V is the mains voltage. A GMOV™ protector can be placed before the high voltage capacitor should a transient condition occur, to minimize high voltage high current transfer over to the Z_{Module} . Since the GMOV™ protector has a capacitance of less than 2 pF, it does not affect the communication aspect of the circuit.

Equation 1.
$$C_{HV} = \frac{VA_{max}}{2\pi f \times V^2}$$

APPLICATION NOTE

Bourns® PFB Transformer in Narrowband PLC Coupling Circuit Designs for Smart Energy Infrastructure



[Bourns® Model PFB Series PLC Transformers](#)



[Bourns® GMOV™ Hybrid Overvoltage Protection Components](#)

REQUIREMENTS FOR PROTECTION (Continued)

A transformer provides galvanic isolation between its primary and secondary. The high voltage capacitor in conjunction with the leakage inductance of the coupling transformer creates a series resonant coupling circuit. This series resonant circuit forms a second order band pass filter. The center frequency is calculated using Equation 2 where L refers to the series leakage inductance and C refers to the series capacitance.

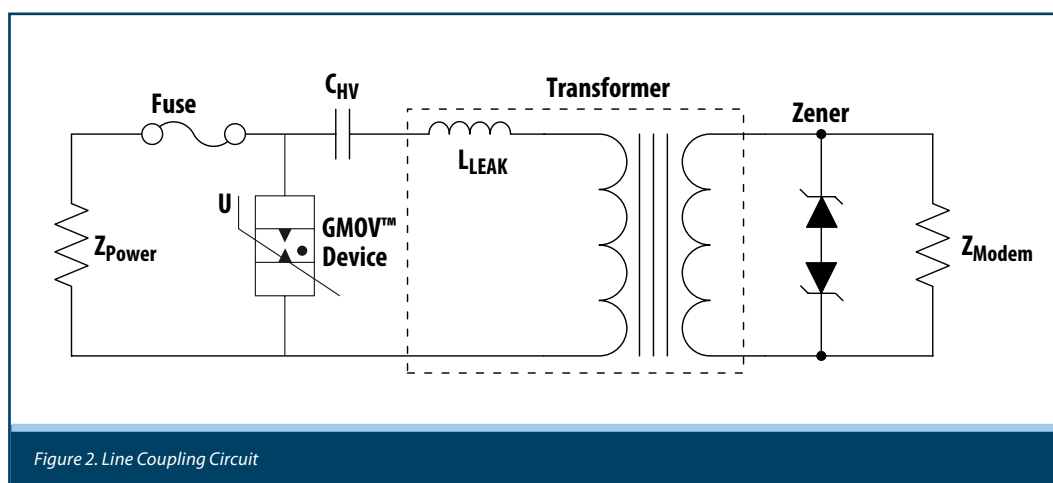

Figure 2. Line Coupling Circuit

Equation 2.
$$f_{res} = \frac{1}{\sqrt{L_{LEAK} C_{HV}}}$$

The frequency bandwidth is determined by low frequency and high frequency -3 dB cut-off points. To measure these points, the respective formulas are given in Equation 3 and Equation 4 where R refers to the terminating resistance.

Equation 3.
$$f_{LF} = \frac{1}{2\pi RC}$$

Equation 4.
$$f_{HF} = \frac{R}{2\pi L}$$

Typically, designs must comply with the European CENELEC EN 50065-1 standard, which defines maximum signal levels as well as permissible carrier frequency bands. Another important design step is to match the modem impedance with the power line impedance. Many times, the modem impedance cannot be changed so designers can tap into the transformer's impedance matching characteristic. In a transformer, the impedance is determined by the component's turns ratio. Knowing this, it is possible to match the modem impedance and power line impedance.

APPLICATION NOTE

Bourns® PFB Transformer in Narrowband PLC Coupling Circuit Designs for Smart Energy Infrastructure



[Bourns® Model PFB Series PLC Transformers](#)



[Bourns® GMOV™ Hybrid Overvoltage Protection Components](#)

PLC SMART METER LINE COUPLING APPLICATION EXAMPLE

Bourns® PFB Series PLC Transformers have been specifically designed to meet the isolation requirements in NB-PLC communication systems, and as stated previously, this series is qualified with the STMicroelectronics® ST8500 programmable PLC modem SoC and STLD1 Line Driver. Figure 3 displays an overview of the components used in a PLC smart meter application.

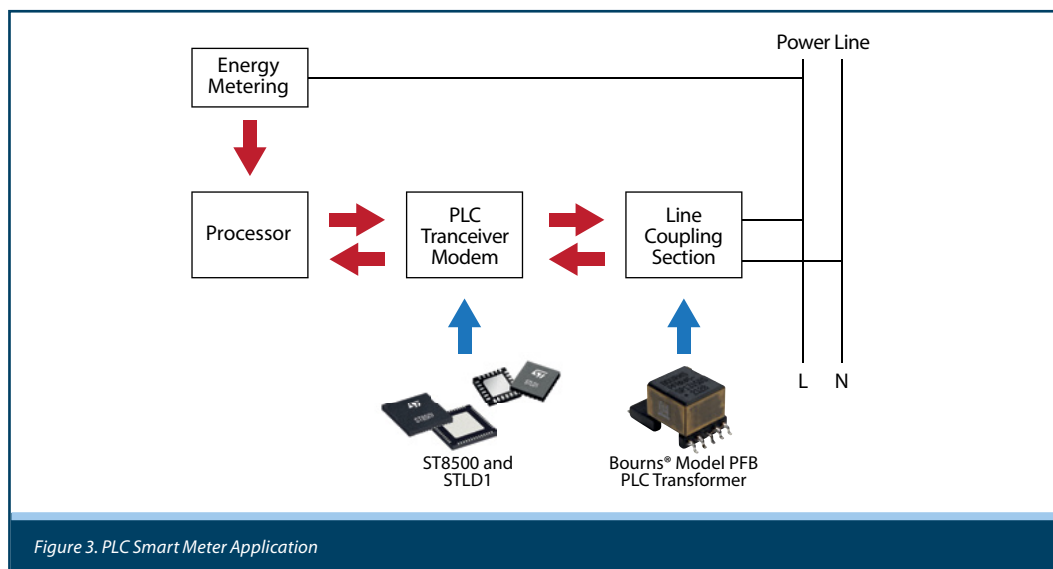

Figure 3. PLC Smart Meter Application

The PFB series PLC transformers from Bourns are available in both a standard and elongated form. The standard Model PFB45-ST13150S transformer is designed for use in areas where the application is located in a secure housing, whereas the Model PFB45-SP13150S device, with added safety features, is designed for use in areas where maintenance workers or users may have access to it. The reinforced insulation of the PFB45-SP13150S transformer provides protection against electric shock and isolates the end user from hazardous input voltages.

Table 1. STMicroelectronics Transformer Requirements

Model	Primary Inductance	Leakage Inductance	DCR	Turns Ratio	Interwinding Capacitance	Insulation Type
PFB45-ST13150S Standard	1 mH	2 μ H Max.	500 m Ω Max.	1:1 Center tap on secondary side	30 pF Max.	Functional
PFB45-SP13150S Elongated	1 mH	2 μ H Max.	500 m Ω Max.	1:1 Center tap on secondary side	30 pF Max.	Reinforced

Table 1 displays the key electrical parameters of Bourns® PFB series PLC transformers. Based on the design steps outlined in the “Designing Isolation for the Line Coupling Circuit” section above, the PFB series transformers provide a straightforward and effective isolation solution for a PLC coupling circuit.

APPLICATION NOTE

Bourns® PFB Transformer in Narrowband PLC Coupling Circuit Designs for Smart Energy Infrastructure



Bourns® Model PFB Series
PLC Transformers



Bourns® GMOV™ Hybrid
Overvoltage Protection
Components

PLC SMART METER LINE COUPLING APPLICATION EXAMPLE (Continued)

Table 2 shows the available GMOV™ component specifications. For the PLC voltage of 120 VAC, the recommended solution is to specify Model GMOV-14D151K or Model GMOV-14D321K for the 240 VAC system. For higher surge current, a 20 mm model would allow up to 10 kA of 8/20 μs of I_{max} . If the PLC system is higher than 240 VAC, please consult with a Bourns Field Applications Engineer for further suggestions on the discrete component combination for superior protection.

Table 2. GMOV™ Component Electrical Characteristics

Bourns Part No.	Operating				Protection						
	Max. Continuous Operating Voltage (MCOV)		Max. Leakage @ MCOV	Max. Capacitance	I_{nom} UL 1449/4th.	I_{max}	Ring Wave Surge IEEE 62.41	Protection Level Current Class (1) IEC 61051-1		Clamp Transition Time	Energy 8/20 μs
	V_{rms}	V_{dc}	A_{rms}	1 MHz	15 Ops.	1 Op.	200 A	Max.	Typ.		
	V	V	μA	pF	A	A	Ops.	V_{fp}	V_c	μs	J
GMOV-14D450K	45	56	< 1	4	3,000	6,000	± 250	900	150	0.3	24
GMOV-14D500K	50	65	< 1	4	3,000	6,000	± 250	800	150	0.3	27
GMOV-14D650K	65	85	< 1	4	3,000	6,000	± 250	800	185	0.3	33
GMOV-14D950K	95	125	< 1	4	3,000	6,000	± 250	800	270	0.3	53
GMOV-14D111K	115	150	< 1	4	3,000	6,000	± 250	800	320	0.3	60
GMOV-14D131K	130	170	< 1	4	3,000	6,000	± 250	800	360	0.3	70
GMOV-14D141K	140	180	< 1	4	3,000	6,000	± 250	950	380	0.3	78
GMOV-14D151K	150	200	< 1	4	3,000	6,000	± 250	950	420	0.3	84
GMOV-14D171K	175	225	< 1	4	3,000	6,000	± 250	950	470	0.3	99
GMOV-14D231K	230	300	< 1	4	3,000	6,000	± 250	1,300	620	0.3	130
GMOV-14D251K	250	320	< 1	4	3,000	6,000	± 250	1,300	675	0.3	140
GMOV-14D271K	275	350	< 1	4	3,000	6,000	± 250	1,300	730	0.3	155
GMOV-14D301K	300	385	< 1	4	3,000	6,000	± 250	1,300	800	0.3	175
GMOV-14D321K	320	415	< 1	4	3,000	6,000	± 250	1,300	875	0.3	180
GMOV-20D450K	45	56	< 1	4	5,000	10,000	± 250	950	150	0.3	49
GMOV-20D500K	50	65	< 1	4	5,000	10,000	± 250	900	150	0.3	56
GMOV-20D650K	65	85	< 1	4	5,000	10,000	± 250	900	185	0.3	70
GMOV-20D950K	95	125	< 1	4	5,000	10,000	± 250	900	270	0.3	106
GMOV-20D111K	115	150	< 1	4	5,000	10,000	± 250	950	320	0.3	130
GMOV-20D131K	130	170	< 1	4	5,000	10,000	± 250	950	360	0.3	140
GMOV-20D141K	140	180	< 1	4	5,000	10,000	± 250	950	380	0.3	155
GMOV-20D151K	150	200	< 1	4	5,000	10,000	± 250	950	420	0.3	168
GMOV-20D171K	175	225	< 1	4	5,000	10,000	± 250	950	470	0.3	190
GMOV-20D231K	230	300	< 1	4	5,000	10,000	± 250	1,300	620	0.3	255
GMOV-20D251K	250	320	< 1	4	5,000	10,000	± 250	1,300	675	0.3	275
GMOV-20D271K	275	350	< 1	4	5,000	10,000	± 250	1,300	730	0.3	305
GMOV-20D301K	300	385	< 1	4	5,000	10,000	± 250	1,300	800	0.3	350
GMOV-20D321K	320	415	< 1	4	5,000	10,000	± 250	1,300	875	0.3	360

(1) Front Level Protection (V_{fp}) defined as measured with 10% of peak current in accordance with IEC 61051-1.

Please note that this Bourns protection recommendation has not been tested on a circuit using any of the STMicroelectronics devices or line drivers mentioned above.

APPLICATION NOTE

Bourns® PFB Transformer in Narrowband PLC Coupling Circuit Designs for Smart Energy Infrastructure



[Bourns® Model PFB Series
PLC Transformers](#)



[Bourns® GMOV™ Hybrid
Overvoltage Protection
Components](#)

CONCLUSION

PLC technology has shown to be beneficial for smart energy infrastructure applications because of its ability to provide reliable, real-time measurements and efficient system control. The deployment of this technology has also proven to be cost-effective, as the communication medium used is existing power lines and, therefore, minimizes the need for additional infrastructure.

Bourns® PFB series PLC transformers are designed to meet the isolation requirements in a growing number of applications that employ PLC line coupling circuits such as in smart meter and smart automation equipment. With superior protection and low capacitance, the GMOV™ hybrid protection component stands ready for unexpected transients or surges up to rated limits that may affect the communication of the line. This application note has presented a streamlined design process for adding isolation to the coupling circuit, highlighting the need to specify a transformer that has the advanced features necessary for these important applications.

www.bourns.com

BOURNS®

Americas: Tel +1-951 781-5500
Email americus@bourns.com

EMEA: Tel +36 88 885 877
Email eurocus@bourns.com

Asia-Pacific: Tel +886-2 256 241 17
Email asiacus@bourns.com

COPYRIGHT © 2023 • BOURNS, INC. • 09/23 • e/K2356

"Bourns" and "GMOV" are registered trademarks of Bourns, Inc. in the U.S. and other countries.
"STMicroelectronics" is registered in the US Patent and Trademark Office.