

# **IMPORTANT CONSIDERATIONS WHEN SELECTING A FAN FOR FORCED AIR COOLING**

*By: Jeff Smoot*

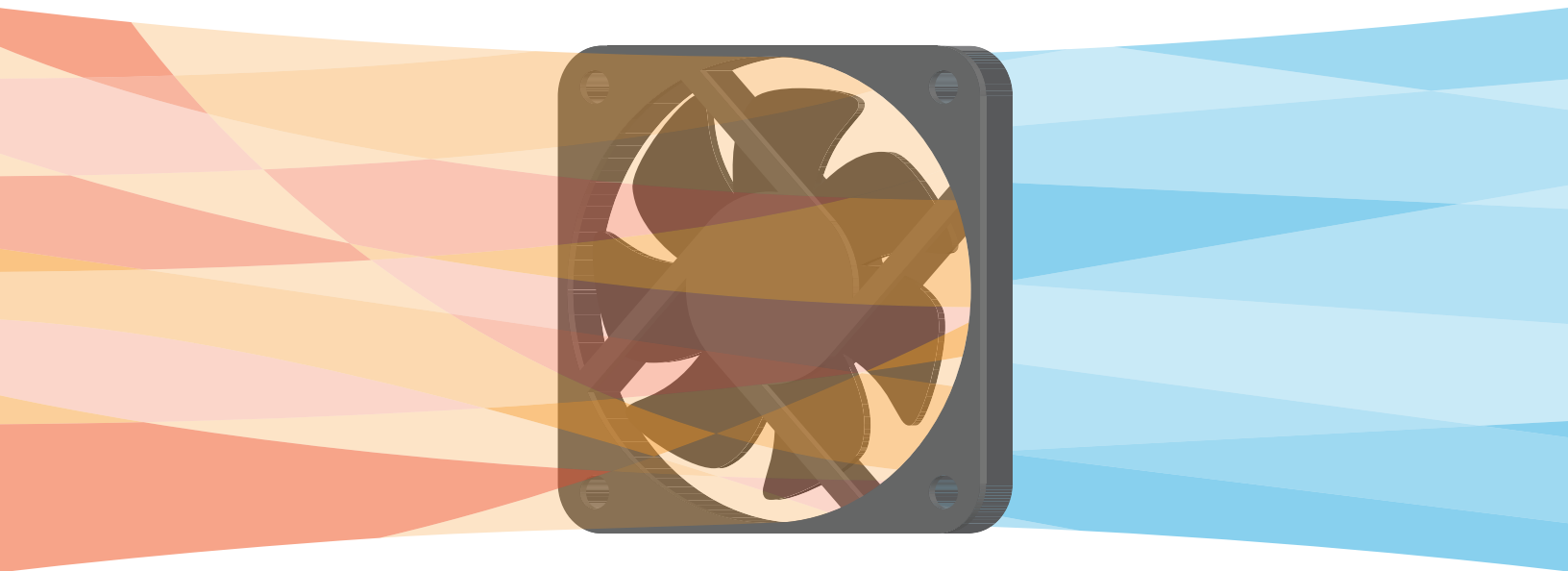

**CUI** DEVICES

*Designing an appropriate thermal management solution requires a systemic approach; each component on a circuit board will consume some power and, in turn, contribute to the overall operating temperature. Most electronic components are designed to work across a specific temperature range, but each one will have its limits and its own unique thermal profile. Cooling technology comes in many forms, but all make use of the fundamentals of conduction, convection and radiation for removing unwanted heat. Understanding the thermal path for removing excess heat in a system is the first step towards designing an efficient thermal solution.*

*In most systems, particularly those that employ an enclosure, some form of forced air cooling will be required to optimize the basic cooling methods available and to ultimately remove heat from the system. Invariably this will involve a fan of some kind and there are now many options to choose from. Selecting the right fan for the thermal management of an enclosed PCB is critical, as its efficiency and effectiveness can have a significant impact on the overall lifespan of a system.*

## **THE COOLING IMPERATIVE**

The heat generated by passive components, integrated semiconductors and other solid state devices is a by-product of their operation. Despite the efforts to produce ultra-low power microcontrollers, the inescapable fact is that the movement of charge carriers in a substrate generates heat. This points a finger at both the cause of the heat and the necessity for effective heat management. Passive devices, predominantly power resistors, have a maximum operating temperature, while most active devices, such as power transistors, can tolerate a maximum junction temperature. In order to avoid cataclysmic failure it is necessary to maintain an ambient temperature low enough to ensure the safe operation of all components in a system.

Conduction of heat away from components throughout the PCB is the simplest means to remove heat. However, when an electronic assembly is placed within an enclosure such as a rack-mount, heat dissipation through conduction becomes less effective. For this reason, assemblies that consume as little as 25 W of power may require forced-air cooling.

## **SYSTEM PROFILING**

To design an appropriate cooling solution, it is imperative to create a thermal profile of the system operating under all conditions in order to understand where and how much heat is generated. This can be achieved by using temperature sensors distributed around a PCB and within an enclosure, which provides the data necessary to move to the next stage, defining the amount of cooling required.

Figure 1:  
An example of a  
computational fluid  
dynamics analysis  
(CFD) which will  
provide a very  
accurate profile of  
cooling requirements

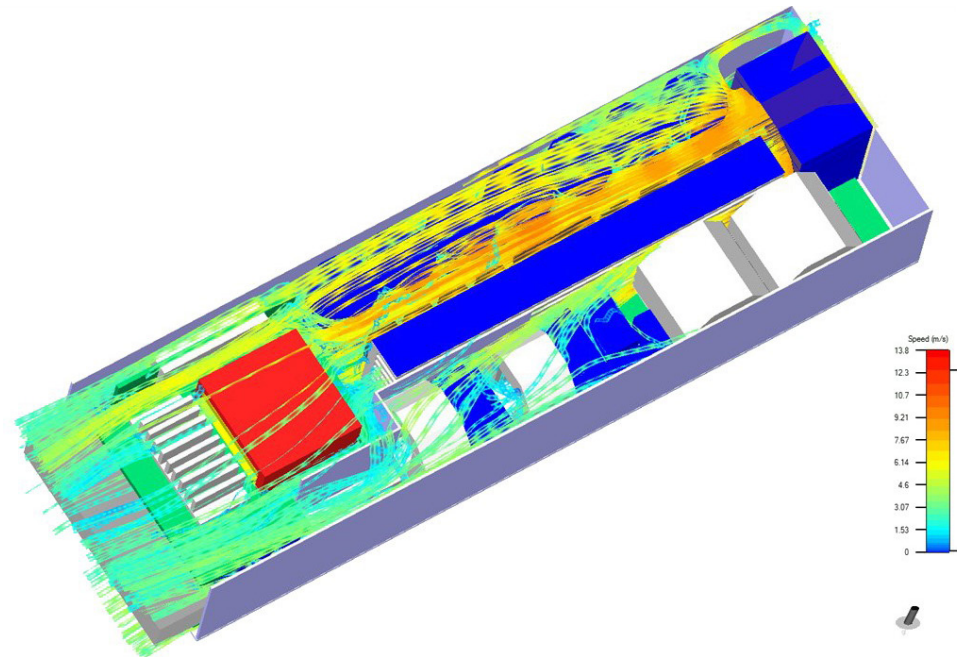

Another important aspect of system profiling is determining the amount of impedance to airflow a system exhibits. The system impedance, in terms of a drop in air pressure between inlet and outlet, plays a major part in calculating the overall airflow required from a fan and, in turn, the size and type of fan that should be designed in. Determining system impedance can be achieved by measuring the pressure drop using sensors or, if possible, by placing the system in an air chamber.

For larger systems, such as data centers, modeling the system using computational fluid dynamics, or CFD, provides an even more accurate profile of a system's cooling requirements.

## **DETERMINING COOLING REQUIREMENTS**

As described, effective thermal management of critical electronic components can be achieved using appropriate levels of forced air cooling, but what is 'appropriate'? To answer this, it is necessary to examine and understand by how much the internal temperature can change without increasing the risk of failure.

It is important to assess a design to determine the 'most critical' component in terms of operating temperature; this will give a maximum ambient temperature. The cumulative

power dissipation for all relevant components, such as power transistors, microprocessors, amplifiers and communication interfaces, will provide a figure for the amount of power dissipated by the overall design.

Power dissipated, in Watts, converts linearly to energy, in Joules/second, which is in turn exhibited as heat. It can be assumed that the temperature of the air around the components will continue to rise all the time the equipment is operating and at some point will reach a level that will inhibit further heat from being removed. Replacing the heated air with ambient air using forced air cooling is clearly the desired effect, which is why it is crucial to specify a fan that can produce the appropriate level of airflow for the system.

Equation 1 shows the relationship between temperature rise and airflow, where  $q$  is the amount of heat absorbed by the air (W),  $w$  is the mass flow of air (kg/s),  $C_p$  is the specific heat of air (J/kg · K) and  $\Delta T$  is the temperature rise of the air (°C).

**EQUATION 1: CALCULATING HEAT ABSORPTION**

$$q = w \times C_p \times \Delta T$$

Once the maximum permissible temperature within the enclosure is known and the amount of heat generated is derived (based on the cumulative power/heat dissipated by the components) it is possible to calculate the amount of airflow required. Since mass flow ( $w$ ) = air flow ( $Q$ ) x density ( $\rho$ ), substituting and solving for  $Q$  we can rewrite Equation 1 to get Equation 2 (where  $Q$  is the airflow in CMM (m<sup>3</sup>/min),  $q$  is the amount of heat to be dissipated (W) and  $\rho$  is the density of air (kg/m<sup>3</sup>)).

**EQUATION 2: CALCULATING THE AMOUNT OF AIRFLOW REQUIRED**

$$Q = [q/(\rho \times C_p \times \Delta T)] \times 60$$

Substituting constants for  $C_p$  and  $\rho$  at 26°C, we can arrive at a general equation for calculating airflow, as shown in Equation 3.

**EQUATION 3: SIMPLIFIED EQUATION FOR CALCULATING AIRFLOW**

$$Q = 0.05 \times q/\Delta T; \text{ for } Q \text{ in CMM}$$

$$Q = 1.76 \times q/\Delta T; \text{ for } Q \text{ in CFM}$$

The calculated airflow figure can now be compared against the specification for a fan. As shown in Figure 2, manufacturers characterize fans using these two parameters, to provide a performance graph that accurately plots airflow (measured in either Cubic Feet per Minute, CFM, or Cubic Meters per Minute, CMM) against static pressure (measured in either inches or millimeters of water, often written as Inch H<sub>2</sub>O or mm H<sub>2</sub>O).

Figure 2:  
Typical performance  
curve of an axial fan

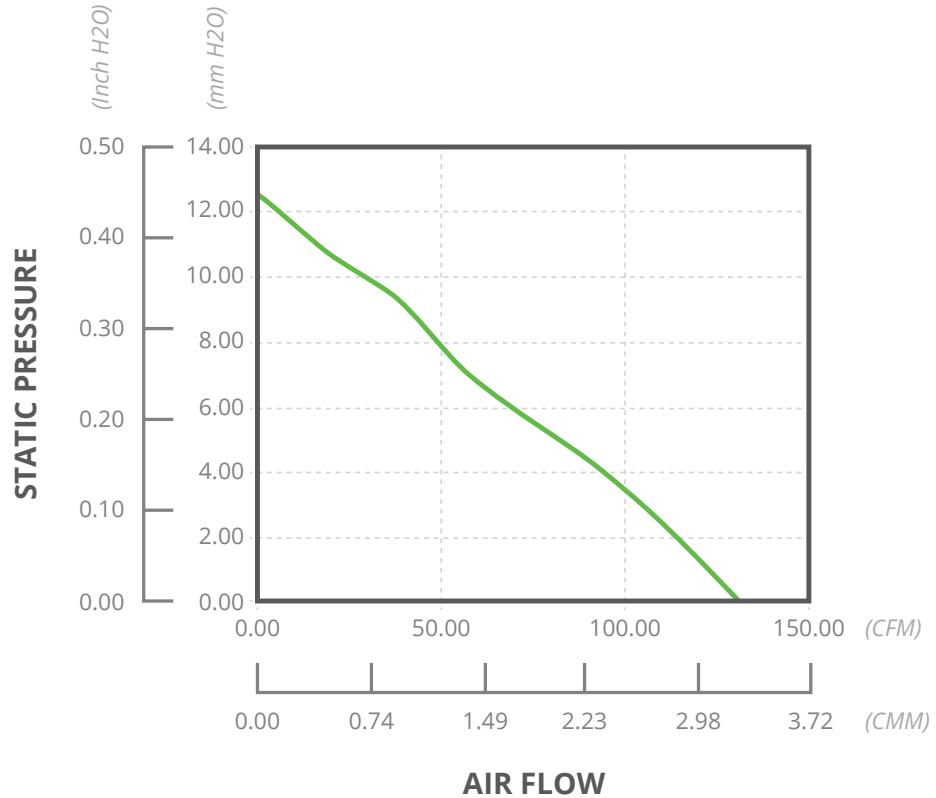
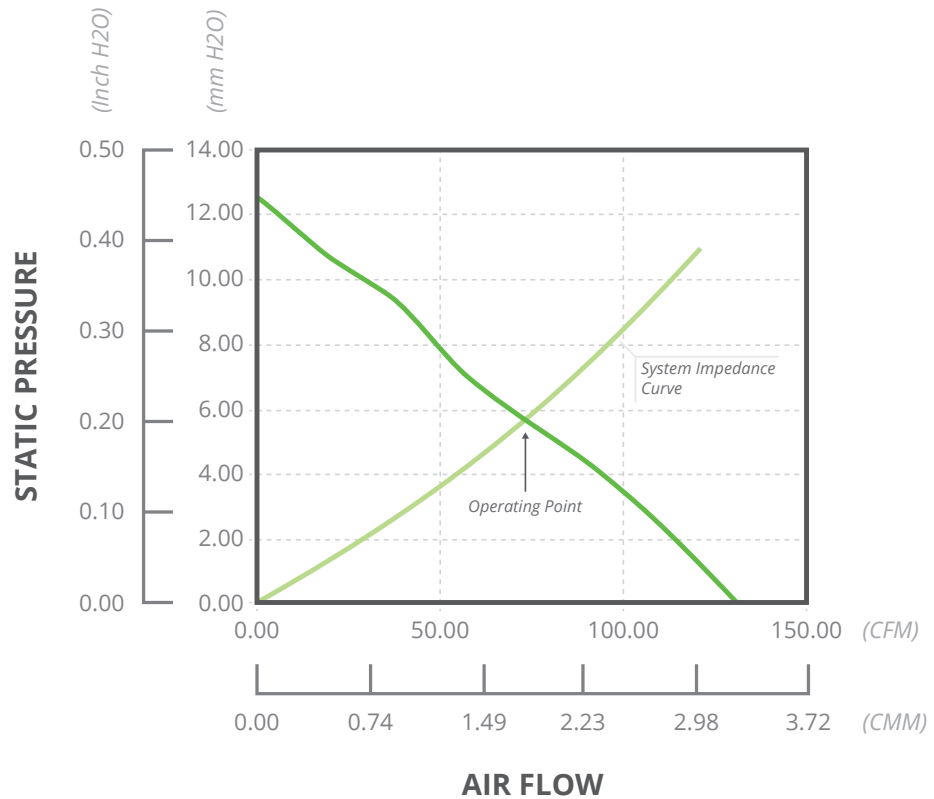

Figure 2 shows the performance curve of the [CFM-120 Series](#) from CUI Devices, a 120 mm by 120 mm frame axial fan with dual ball bearing construction. Unfortunately, the result given by Equation 3 is only accurate for ‘ideal’ conditions; with no back pressure from the enclosure (known as System Impedance, as covered earlier). In reality there will always be some system impedance, so in order to determine the real world requirements it is paramount to calculate or estimate the system impedance. This can then be plotted on the fan’s performance curve (Figure 3) and the point at which they cross should be taken as the operating point for the fan.

As outlined earlier, measuring the airflow through an enclosure can be achieved using an airflow chamber, but if that is not an option the alternative is to specify the operating point above the figure derived from Equation 3. For example, if the airflow calculated is 50 CFM with zero back pressure, over-specifying the fan such that it produces a maximum of 100 CFM with the intention of operating it at 75 CFM would provide a good margin of error, as well as some headroom for increasing airflow during operation.

Figure 3:  
The performance curve of an axial fan with System Impedance plotted, showing the Operating Point



Taking steps at the design stage to decrease or minimize system impedance can clearly be beneficial in terms of specifying the size and power of a fan. At a minimum, it is good practice to keep the areas around the air inlet and outlet as clear of components as possible and to consider the additional system impedance a filter will introduce. Component placement on the PCB should encourage airflow to and around critical components, using guides if needed.

In addition, it should be appreciated that the above equations also use air density at sea level. If a system is expected to be used at altitudes significantly above sea level it is crucial that this is taken into account. Air density reduces with altitude, so a significant increase in altitude would result in a correspondingly significant increase in airflow required to maintain the same level of cooling.

## **CHOOSING THE RIGHT FAN DESIGN**

As well as being available in both ac and dc configurations, fans are generally categorized by the way the air enters and leaves the fan; if it exits in the same plane as it enters it is normally termed an axial fan, as to draw air in from one side and expel it from the other. If the airflow leaves in a different plane it is normally referred to as a centrifugal design, as the air drawn in changes direction inside the fan and is expelled in a different direction. This style of fan can effectively compress the air, allowing it to deliver a constant airflow under different pressures. Perhaps the most prolific centrifugal fan design is the blower, which resembles an axial fan but typically expels air at 90° to the intake.

The volume of airflow needed and the static pressure of the system will influence the most appropriate style of fan for a given application. Axial fans are predominantly suitable for high airflow in systems with low static pressure, while centrifugal fans offer lower airflow, but can deliver it against higher static pressure.

Both audible and electrical noise are also important considerations when selecting a fan. While the advantages of using a dc fan have been touted above, often these benefits are in direct competition with the audible noise generated by their operation. The general rule of thumb being the greater the airflow required, the greater the audible noise. Thus, axial fans will typically have lower audible noise than a blower. Careful design to optimize airflow and reduce system impedance, thus reducing the required CFM, are critical in order to minimize the audible noise generated.

In addition to audible noise, dc fans can have other unwanted system effects. The dc motor within the fan does create an electromagnetic interference (EMI) signature. EMI generated by the fan is normally limited to conducted EMI in the power leads. This can generally be effectively suppressed with ferrite beads, shielding or filtering. For most PCB based systems in an enclosure, the dc axial fan provides the right balance between cost, audible noise, electrical noise (EMI) and performance.

There are differences in the construction of axial fans that may also be relevant depending on the application. Specifically these differences relate to the bearings, which are either steel ball bearings or sintered powdered bearings, usually referred to as sleeve bearings. At consistently low temperatures, sleeve bearings can operate as well as ball bearing fans, however at variable or high temperatures ball bearings have been shown to operate longer and more reliably. Sleeve bearing fans, which are normally cheaper than ball bearing fans, do have their place, but their relatively shorter lifetime and propensity to failure at high temperatures limits their overall suitability.

As an alternative to sleeve or ball bearings, CUI Devices has developed the [omniCOOL™ system](#), an advanced sleeve bearing design that bridges the cost-performance gap

between traditional bearings on the market. This technology incorporates a magnetic structure that enables rotor-balancing to minimize tilt, wobble, and friction, allowing for operation at any angle. It also integrates a specially hardened sleeve that provides additional heat resistance and extends operational life, while decreasing fan noise and friction due to a reduced need for lubricant. In addition, the omniCOOL system's simple design makes it easier to manufacture, more reliable, and more cost-effective than more complex designs.

## ACTIVE CONTROL AND VARIABILITY

Axial fans are widely used in rack-mount enclosures thanks to their combination of small size, low power and high airflow. Many also include additional features that can further improve system performance by providing greater control over the speed of operation, thereby optimizing a design for overall power consumption. As described, calculating the minimum airflow rate required to cool a PCB housed within an enclosure allows for the specification of a fan that can deliver adequate cooling under all conditions. This assumes that the fan will run constantly, even when maximum cooling is not required. While this is not likely to result in failure, it does assume worst-case conditions at all times and is therefore inefficient from a system point of view and will also reduce the operating lifetime of the fan.

Because of this it has become common practice to monitor the temperature within an enclosure and only turn a fan on when it is required. While this approach can improve the lifespan of the fan and reduce audible noise, it can present problems in terms of thermal lag. It can also introduce a fault condition if for some reason the fan is unable to start due to an obstruction in the fan.

To address this, modern dc axial fans like the CFM-V and CFM Series from CUI Devices include auto-restart protection as a standard feature. This feature detects when the fan motor is prevented from rotating and automatically cuts the drive current. Models including the

Figure 4:  
Diagram to illustrate  
how the signal  
supports speed  
detection

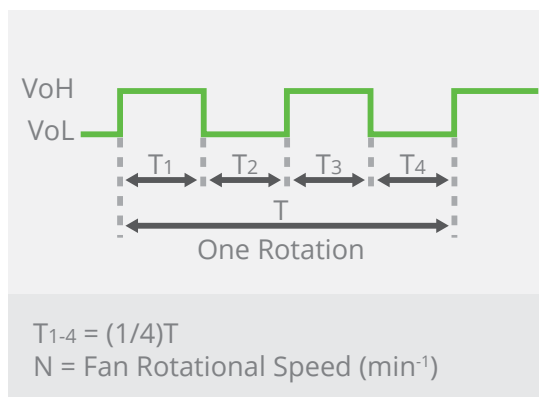
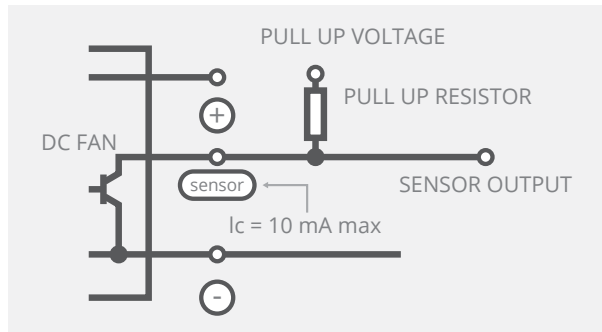



Figure 5:  
Diagram to illustrate output signal indicating stall/lock fault



[CFM-60V Series](#) also offer optional controls such as tachometer and rotation detection sensors. The tachometer detects the rotational speed of the fan motor and provides a pulsed output that can be used within control circuitry (see Figure 4). If the motor stops, the output stops pulsing and stays at either a logic high or logic low. The rotation detection feature doubles as a lock sensor; if the fan motor stops, the output is driven to a logic high and remains at a logic low during normal operation (Figure 5).

In addition, there is the ability to control the speed of the fan using Pulse Width Modulation (PWM); the duty cycle of this input determines the speed of the fan’s rotation, the relationship between the duty cycle and whether the fan’s speed is linear. When used in conjunction with a simple algorithm running on a microcontroller it is possible to create a sophisticated thermal management solution that can adapt to system conditions and provide more efficient operation.

A simple example of implementing fan control could consist of a single or multiple temperature sensors distributed around a board. Many modern ICs now include temperature sensors, which can be used for this purpose. Using zones provides greater visibility into the system, particularly for components most susceptible to heat variations. As soon as the measured temperature approaches a predetermined level, the fan can be turned on or speed can be increased by changing the duty cycle of the PWM signal to provide the necessary cooling (see Figure 6). Correspondingly, the fan’s speed can be reduced if the internal temperature is below an acceptable level.

Figure 6:  
Changing the fan speed can be achieved by changing the duty cycle of the PWM signal

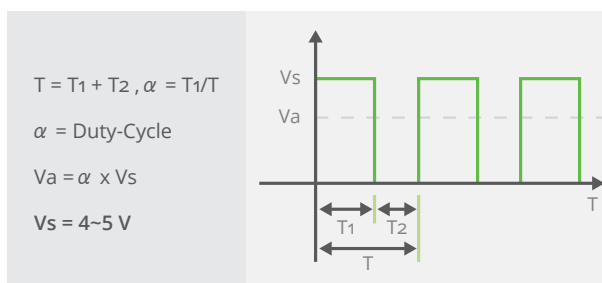

## **CONCLUSION**

Forced air cooling is an efficient way of implementing effective thermal management for an enclosed PCB and choosing the correct fan for the application is vital. With semiconductors and PCBs becoming ever more complex and dense, if a component fails, statistically it will be because it overheated or operated for too long at a critical junction temperature. If the level of forced air cooling is insufficient for the system's needs, the fan will most definitely be the main cause of failure, even though that failure will typically manifest itself as some other critical component failing. With so much to risk, selection of the right fan should not be approached casually and can be the difference between a premature failure and an efficiently operating system.



*View CUI Devices' full line of dc fans and blowers*

**LEARN MORE ►**