

UWB Module Data Sheet

NXP SR150 Chipset

Design Name: Type2BP
P/N : LBUA0VG2BP-741

Confidential

< Specification may be changed by Murata without notice >
Murata Manufacturing Co., Ltd.

Revision History

Revision Code	Date	Description	Comments
-	2020.11.26	First Issue	
A	2021.8.17	2 Key Features 7.1 Pin Assignment 7.2 Pin Description 10.1 Power on sequence 11 Host Interface (SPI) 12 DC/RF Characteristics 14. Tape and Reel Packing	-Updated -Updated -Updated -Added -Added -Updated -Updated
B	2022.1.11	2 Key Features 6. Dimensions, Marking and Terminal Configurations 10. System power status and power sequence 12 DC/RF Characteristics 13. Recommended land pattern 14. Reference Circuit	-Updated -Updated -Added/Updated -Updated -Added -Updated
C	2022.2.4	12.3 Calibration data in OTP	-Updated
D	2022.10.21	5.1 Radio Certification Appendix	-Updated -Added
E	2022.11.29	Appendix	-Revised
F	2022.12.9	10.1 System modes 10.3 Power mode entry and exit conditions 10.5 Power Timing diagrams	-Updated -Updated -Updated
G	2023.1.10	3 Ordering Information	-Updated
H	2023.4.20	14. Reference Circuit	-Updated

TABLE OF CONTENTS

Revision History.....	1
1. Scope	3
2. Key Features	3
3. Ordering Information	3
4. Block Diagram	3
5. Certification Information	4
5.1. Radio Certification	4
6. Dimensions, Marking and Terminal Configurations	5
7. Module Pin Descriptions	6
7.1. Pin Assignments	6
7.2. Pin Description.....	7
8. Absolute Maximum Ratings.....	9
9. Operating Conditions.....	9
9.1. Operating conditions.....	9
9.2. Digital I/O Requirements	9
10. System power status and power sequence	11
10.1. System Modes.....	11
10.2. State Diagram and Power modes	11
10.3. Power mode entry and exit conditions	12
10.4. Power management block.....	13
10.5. Power Timing diagrams.....	13
10.5.1 Deep Power-down (DPD) sequence.....	14
10.5.2 Hard Power-down (HPD) sequence	15
11 Host Interface (SPI).....	16
12 DC / RF Characteristics.....	18
12.1 Current consumption	18
12.2 Reference data	18
12.3 Calibration value in OTP.....	18
13 Recommended land pattern	19
14 Reference Circuit.....	20
15 Tape and Reel Packing	21
16 NOTICE	25
16.1 Storage Conditions:	25
16.2 Handling Conditions:.....	25
16.3 Standard PCB Design (Land Pattern and Dimensions):	25
16.4 Notice for Chip Placer:.....	25
16.5 Soldering Conditions:.....	26
16.6 Cleaning:.....	26
16.7 Operational Environment Conditions:.....	26
17 PRECONDITION TO USE OUR PRODUCTS	27
APPENDIX	28

 Please be aware that an important notice concerning availability, standard warranty and use in critical applications of Murata products and disclaimers thereto appears at the end of this specification sheet.

1. Scope

This specification is applied to the NXP SR150 UWB module

2. Key Features

- Main IC : NXP / SR150
- Compliant with IEEE802.15.4z HRP PHY
- Supports SHF UWB bands, Ch5 and 9.
- Supports 62.4MHz, 124.8MHz and 249.6MHz PRF mode.
- Data rates of 6.81Mbps, 7.8Mbps, 27.24Mbps and 31.2Mbps.
- Complies with FCC&ETSI UWB spectral masks
- Supports 2-way ranging (DS-TWR) and one way ranging (TDoA)
- Supports 2D and 3D Angle of Arrival (AoA) measurement
- Surface mount type 6.6 x 5.8 mm(Typical), H = 1.2 mm(Max.)
- Weight : 107 mg
- MSL : 3
- RoHS compliant

3. Ordering Information

Ordering Part Number	Description
LBUA0VG2BP-741	MP order
LBUA0VG2BP-SMP	In case of sample order
LBUA0VG2BP-EVK-P	Evaluation Kit

4. Block Diagram

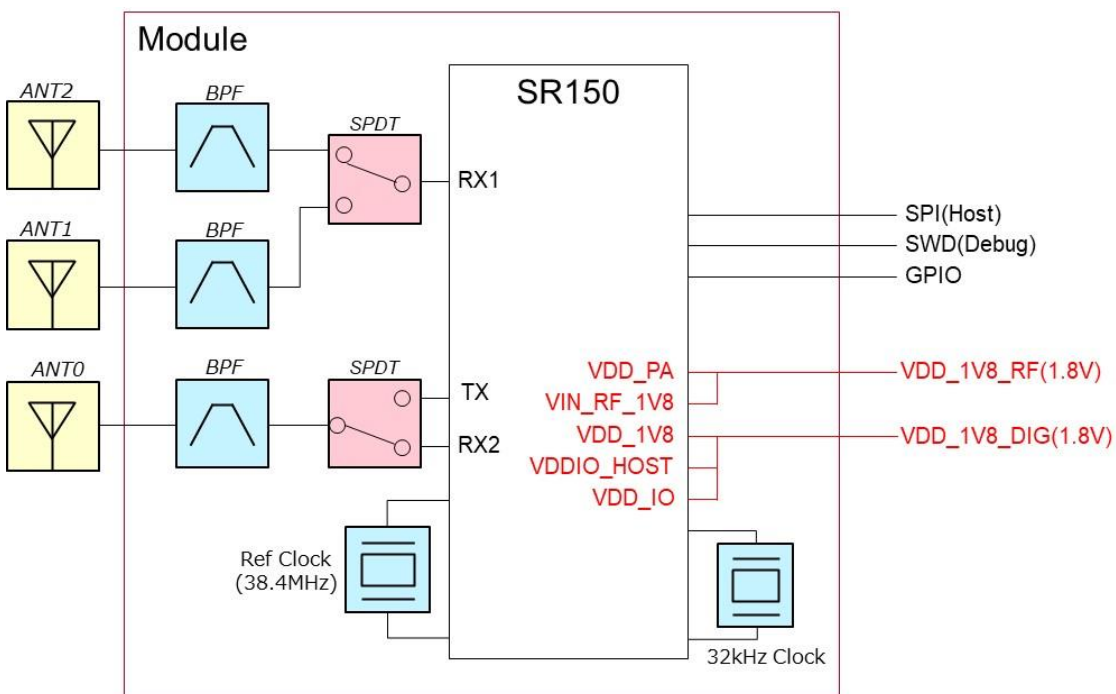

5. Certification Information

5.1. Radio Certification

USA

FCC ID: VPYLB2BP

* Certified diversion is allowed only if the final product is the Hand-held system (PART 15 Subpart F §15.519) and is an exact copy of the antenna used.

Please see Appendix for the antenna registered by Murata.

Canada

IC: 772C-LB2BP

* Certified diversion is allowed only if the final product is the Hand-held system (RSS-220 Section 5.3) and is an exact copy of the antenna used.

Please see Appendix for the antenna registered by Murata.

Europe

EN302065 conducted test report is prepared.

*This test report is for reference only and not applicable to the customer's final product.

Japan

Japanese type certification is prepared.

Ⓜ 003-220111

*Certified diversion is allowed only when the antenna applied for by Murata is used.

6. Dimensions, Marking and Terminal Configurations

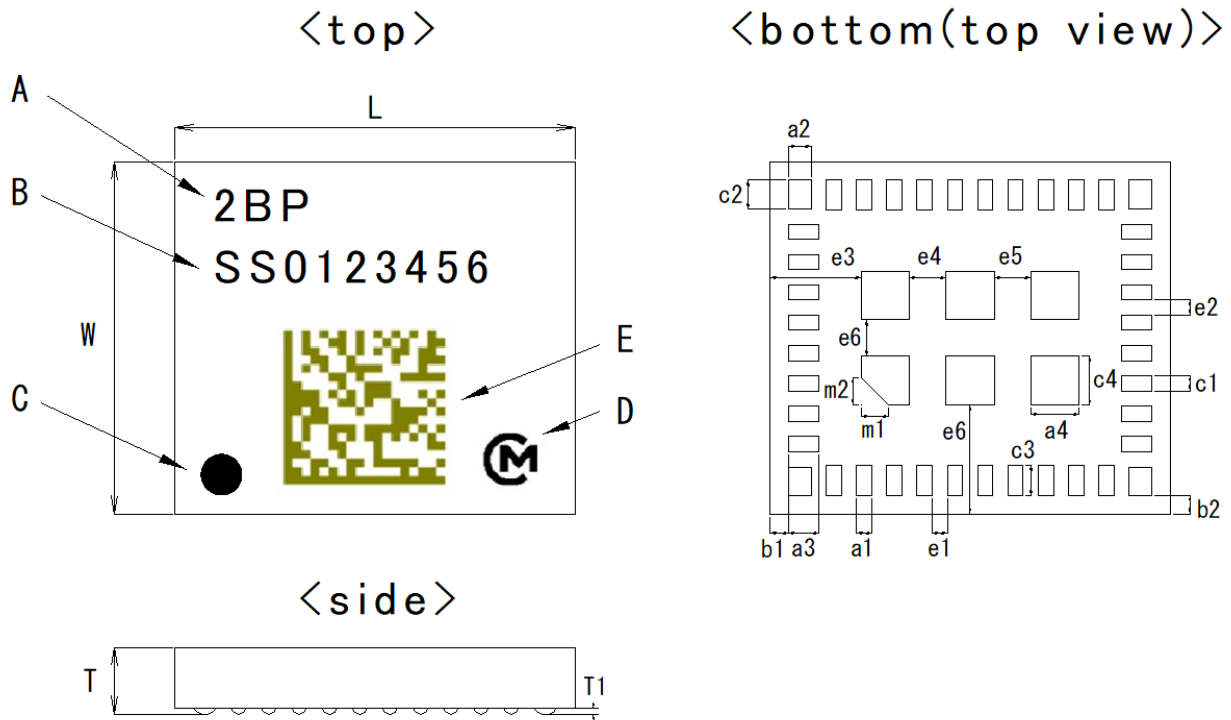

Marking	Meaning
A	Module Type
B	Inspection Number
C	Pin 1 Marking
D	Murata Logo
E	2D Code

(unit:mm)

Mark	Dimensions	Mark	Dimensions	Mark	Dimensions
L	6.6 +/- 0.2	W	5.8 +/- 0.2	—	—
T	1.20 max.	T1	0.045 typ.	—	—
a1	0.25 +/- 0.1	a2	0.375 +/- 0.1	a3	0.5 +/- 0.1
a4	0.8 +/- 0.1	b1	0.3 +/- 0.2	b2	0.3 +/- 0.2
c1	0.25 +/- 0.1	c2	0.475 +/- 0.1	c3	0.5 +/- 0.1
c4	0.8 +/- 0.1	e1	0.25 +/- 0.1	e2	0.25 +/- 0.1
e3	1.5 +/- 0.2	e4	0.6 +/- 0.1	e5	0.6 +/- 0.1
e6	1.8 +/- 0.2	m1	0.45 +/- 0.1	m2	0.45 +/- 0.1

Structure

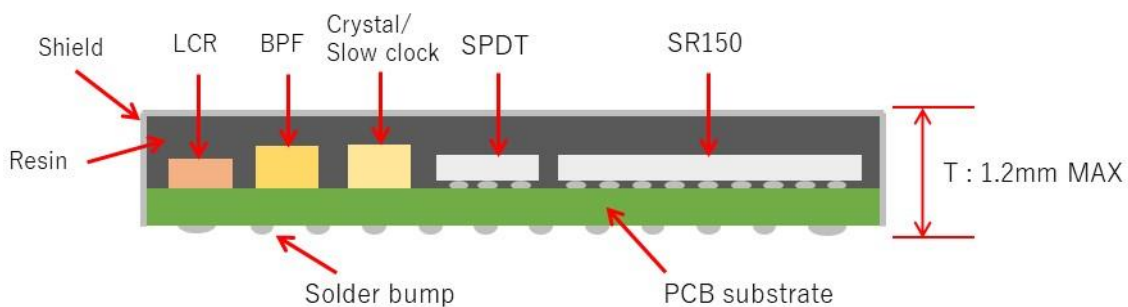

7. Module Pin Descriptions

7.1. Pin Assignments

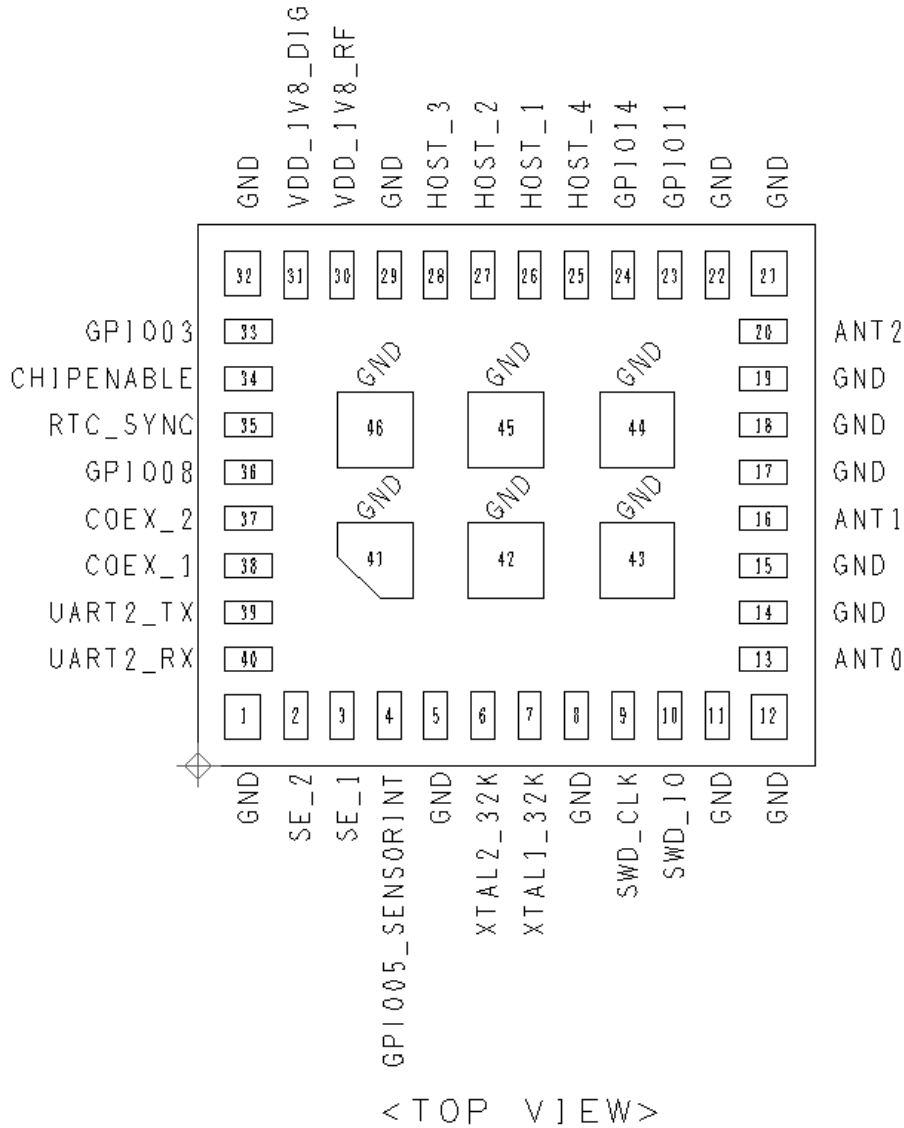

No.	Terminal Name	No.	Terminal Name	No.	Terminal Name	No.	Terminal Name
1	GND	13	ANT0	25	HOST_4	37	COEX_2
2	SE_2	14	GND	26	HOST_1	38	COEX_1
3	SE_1	15	GND	27	HOST_2	39	UART2_TX
4	GPIO05_SENSORINT	16	ANT1	28	HOST_3	40	UART2_RX
5	GND	17	GND	29	GND	41	GND
6	XTAL2_32K	18	GND	30	VDD_1V8_RF	42	GND
7	XTAL1_32K	19	GND	31	VDD_1V8_DIG	43	GND
8	GND	20	ANT2	32	GND	44	GND
9	SWD_CLK	21	GND	33	GPIO03_SYNC	45	GND
10	SWD_IO	22	GND	34	CHIPENABLE	46	GND
11	GND	23	GPIO11	35	RTC_SYNC		
12	GND	24	GPIO14	36	GPIO08		

7.2. Pin Description

No.	Pin Name	Type	Connection to IC pin name	Supply	Description
1	GND				
2	SE_2	I/O	SE_2	VDD_IO	NA Kept open.
3	SE_1	I/O	SE_1	VDD_IO	NA Kept open.
4	GPIO05_SENSORINT	I/O	GPIO05_HOST_INTERRUPT	VDD_IO	IRQ to host for indicating data ready, switching time is 125ns
5	GND				
6	XTAL2_32K	I	XTAL2_32K		Reserved pin for external Xtal option, please leave this pin as NC.
7	XTAL1_32K	I	XTAL1_32K		Reserved pin for external Xtal option, please leave this pin as NC.
8	GND				
9	SWD_CLK	I/O	SWD_CLK		Serial Wire Debug interface clock input. Default configuration is secondary SPI bus clock interface connection SPI_SCK, switching time is 125ns.
10	SWD_IO	I/O	SWD_IO		Serial Wire Debug interface input/output. Default configuration is secondary SPI bus MISO connection, switching time is 125ns.
11	GND				
12	GND				
13	ANT0	RF	TX_OUT / RX2_IN		RF Antenna port, Tx / Rx switched by internal SPDT.
14	GND				
15	GND				
16	ANT1	RF	RX1_IN		RF Antenna port. ANT1 / ANT2 switched by internal SPDT.
17	GND				
18	GND				
19	GND				
20	ANT2	RF	RX1_IN		RF Antenna port. ANT1 / ANT2 switched by internal SPDT.
21	GND				
22	GND				
23	GPIO11	I/O	GPIO11_ANT_CTL1	VDD_IO	General purpose IO, switching time is dependent on the end control point, 125ns when controlled by ARM, 33ns when controlled by the DSP.
24	GPIO14	I/O	GPIO14_ANT_CTL2	VDDIO_HOST	General purpose IO, switching time is dependent on the end control point, 125ns when controlled by ARM, 33ns when controlled by the DSP.
25	HOST_4	I/O	HOST_4	VDDIO_HOST	Host Interface line 4, SPI MISO connection, switching time is 125ns.
26	HOST_1	I/O	HOST_1	VDDIO_HOST	Host Interface line 1, SPI clock line, switching time is 125ns.
27	HOST_2	I/O	HOST_2	VDDIO_HOST	Host Interface line 2, SPI slave connection, switching time is 125ns.
28	HOST_3	I/O	HOST_3	VDDIO_HOST	Host Interface line 3, SPI MOSI connection, switching time is 125ns.
29	GND				

30	VDD_1V8_RF	Power	VDD_PA / VIN_RF_1V8		VDD supply for PA and Vin input to 1.8V RF
31	VDD_1V8_DIG	Power	VDD_1V8 / VDD_IO / VDDIO_HOST		VDD for all Digital LDOs, Host interface and IO pins.
32	GND				
33	GPIO03_SYNC	I	GPIO03_SYNC	VDDIO_HOST	SPI Rx handshake from Host Interface, General purpose IO, switching time is 125ns
34	CHIPENABLE	I	CHIPENABLE	VDD_IO	Connection for disabling/enabling the chip
35	RTC_SYNC	I	RTC_SYNC	VDD_IO	Not used. Kept open
36	GPIO08_eSE	I/O	GPIO08_SE_IRQ	VDD_IO	NA Kept open
37	COEX_2	I/O	COEX_2		NA Kept open
38	COEX_1	I/O	COEX_1		NA Kept open
39	UART2_TX		UART2_TX		NA Kept open
40	UART2_RX		UART2_RX		NA Kept open
41	GND				
42	GND				
43	GND				
44	GND				
45	GND				
46	GND				

8. Absolute Maximum Ratings

Parameter		Min	Max	Unit
Storage Temperature		-40	+85	deg.C
Supply Voltage	VDD_1V8_DIG	-	2.5	V
	VDD_1V8_RF	-	2.5	V

* Stresses in excess of the absolute ratings may cause permanent damage. Functional operation is not implied under these conditions. Exposure to absolute ratings for extended periods of time may adversely affect reliability. No damage assuming only one parameter is set at limit at a time with all other parameters are set within operating condition.

9. Operating Conditions

9.1. Operating conditions

Parameter		Min	Typ	Max	Unit
Operating Temperature Range		-30	+25	+85	deg.C
Supply Voltage	VDD_1V8_DIG	1.71	1.8	1.98	V
	VDD_1V8_RF	1.71	1.8	1.98	V

9.2. Digital I/O Requirements

Pin Characteristics for GPIO's. SPI_SCK, SPI_SS

Symbol	Parameter	Conditions	Min	Typ	Max	Unit
V _{IH}	High level input voltage	VDDIO=1.8V	0.85	-	VDDIO+0.5	V
V _{IL}	Low level input voltage	VDDIO=1.8V	-0.5	-	0.82	V
I _{OH}	Output high current	VOH=VDDIO 1.8V-0.4V	10	-	19.4	mA
I _{OL}	Output low current	VOL=0.4V, VDDIO@1.8V	39	-	58	mA
t _{rise}	Rise time at IO	20% to 80%, VDDIO=1.8V	0.97	-	2.15	ns
t _{fall}	Fall time at IO	80% to 20%, VDDIO=1.8V	1.03	-	2	ns
R _{PU}	Weak Pull-up resistor	VDDIO=0V	40	50	60	kΩ
R _{PD}	Weak Pull-down resistor	VDDIO=1.8V	40	50	60	kΩ
C _{IN}	IO pin capacitance	-	-	-	7	pF

Pin Characteristics for SPI_MISO, SPI_MOSI

Symbol	Parameter	Conditions	Min	Typ	Max	Unit
V _{IH}	High level input voltage	VDDIO=1.8V	0.85	-	VDDIO+0.5	V
V _{IL}	Low level input voltage	VDDIO=1.8V	-0.5	-	0.78	V
I _{OH}	Output high current	VOH=VDDIO 1.8V-0.4V	17	-	33	mA
I _{OL}	Output low current	VOL=0.4V, VDDIO@1.8V	38	-	56	mA
t _{rise}	Rise time at IO	20% to 80%, VDDIO=1.8V	0.4	-	0.6	ns
t _{fall}	Fall time at IO	80% to 20%, VDDIO=1.8V	0.4	-	0.55	ns
R _{PU}	Weak Pull-up resistor	VDDIO=0V	40	48.8	58	kΩ
R _{PD}	Weak Pull-down resistor	VDDIO=1.8V	40	48.8	58	kΩ
C _{IN}	IO pin capacitance	-	-	-	6	pF

10. System power status and power sequence

10.1. System Modes

This module has 6 power modes : HPD (Hard Power Down) mode, DPD (Deep Power Down) mode, Deep power down retention mode, Sleep, Active mode and Hardware configuration Autoload. Here is the description of these modes.

System power state	Description
Active mode	The device is running and supplied by Platform PMU, in this mode several active states are available : Idle, TX, RX and Dual RX.
Deep power down(DPD) retention mode	The device is in low power mode and supplied by the Platform PMU, the memory is supplied, a configured wake up can bring the device back to the Active mode, no RF communication is possible.
Sleep	Specific parts can be active or inactive, this sleep mode can be configured by firmware which enables several power states, no RF communication is possible.
Hard power down(HPD) mode	The device is powered down and supplied by the PMU, it can be activated by the CE (CHIPENABLE) signal.
Hardware configuration Autoload	The device is supplied by the platform PMU and is loading the Hardware configuration and firmware into the memory.

10.2. State Diagram and Power modes

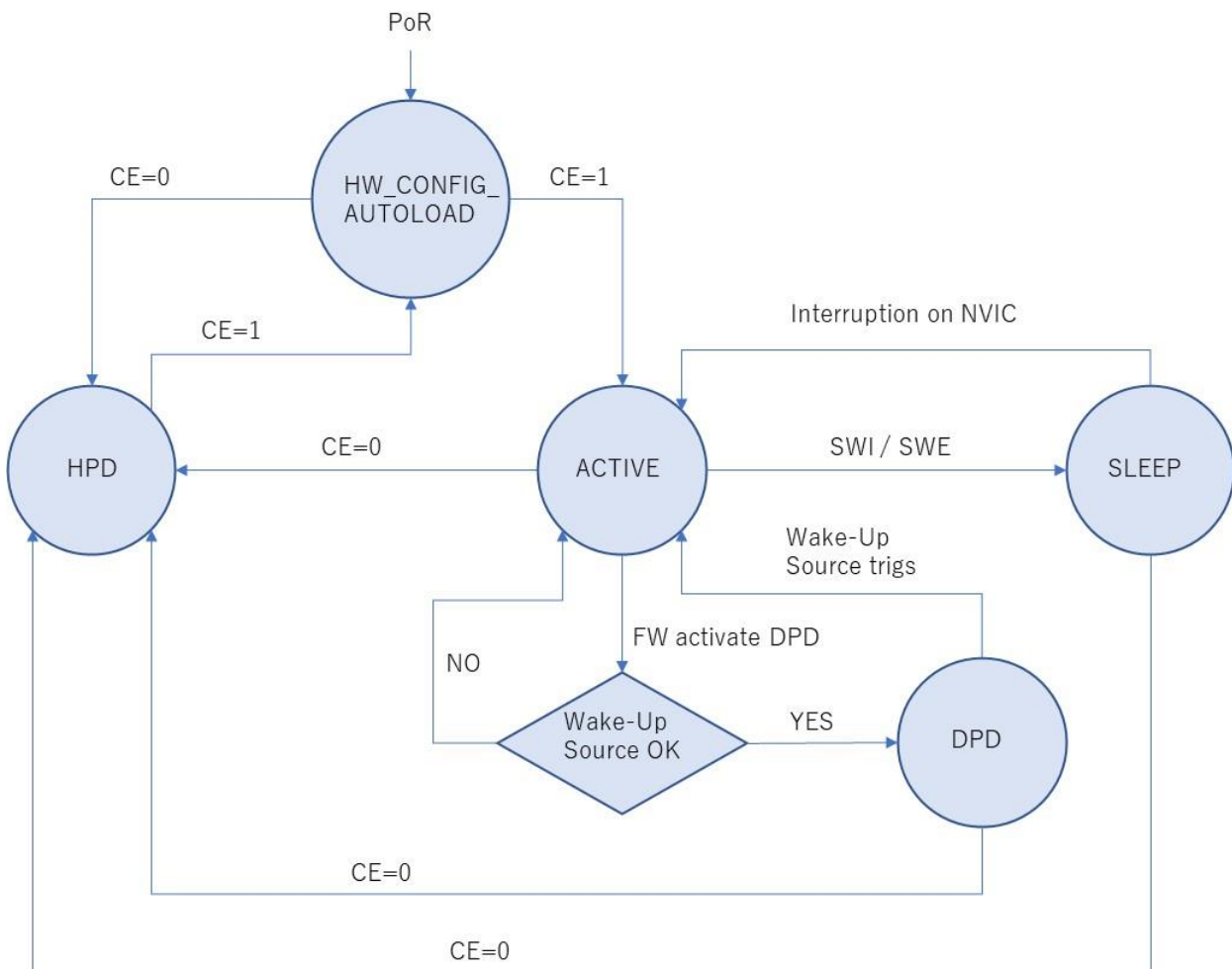

10.3. Power mode entry and exit conditions

Power state	Entry Condition	Exit Condition
HPD	Two possible methods <ul style="list-style-type: none"> • Software command • Assert CE low for > 80us 	<ul style="list-style-type: none"> • Assert CE to high
DPD with memory retention mode	<ul style="list-style-type: none"> • Software command 	Exit to HPD state: <ul style="list-style-type: none"> • Assert CE low for > 80us Exit to Active state: <ul style="list-style-type: none"> • Wake up timer expired • Temperature sensor event • SPI NSS Negative Edge, GPIO(3,5) event.
ACTIVE	<ul style="list-style-type: none"> • End of system boot after wake up • Wake up timer expired • Temperature sensor event • SPI NSS Negative Edge, GPIO(3,5) event. 	<ul style="list-style-type: none"> • Software command • Assert CE low for > 80us

The time required for the module to go into DPD state is < 100us controlled by the firmware. The required time for the module to enter HPD state is less then 100us starting for the instance that CE is de-asserted, in both modes VDD_1V8_DIG is turned off. The Wakeup timing from DPD state is around 370us, the wakeup from HPD state is triggered once CE is asserted and takes around 380us.

Here is typical system power cycle image.

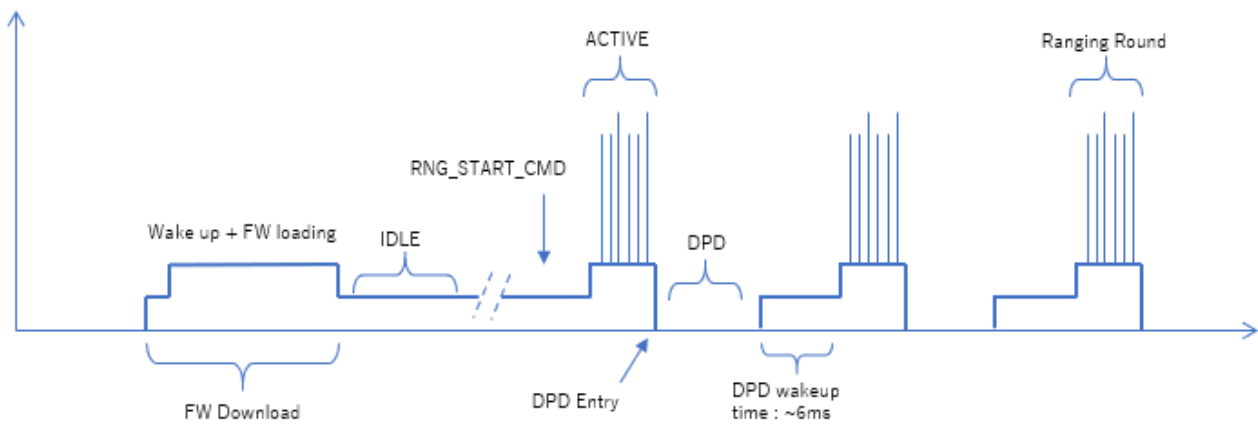

10.4. Power management block

The Power management unit of SR150 in this module generates following internal supplies required by SR150 system out of VDD_1V8 input supply voltage (VDD_1V8 supplied by VDD_1V8_DIG pin of this module).

VDD_AON : Digital output supply voltage for Always ON logic

VDD_LP : Digital output supply voltage for LP Logic

VDD_AM : Digital output supply voltage for retaining ARM Subsystem memories

VDD_MM : Digital output supply voltage for retaining BB Subsystem memories

VDD_DIG : Digital output supply voltage for powering BB Subsystem

VDD_DIG_BB : Digital output supply voltage for powering BB Subsystem

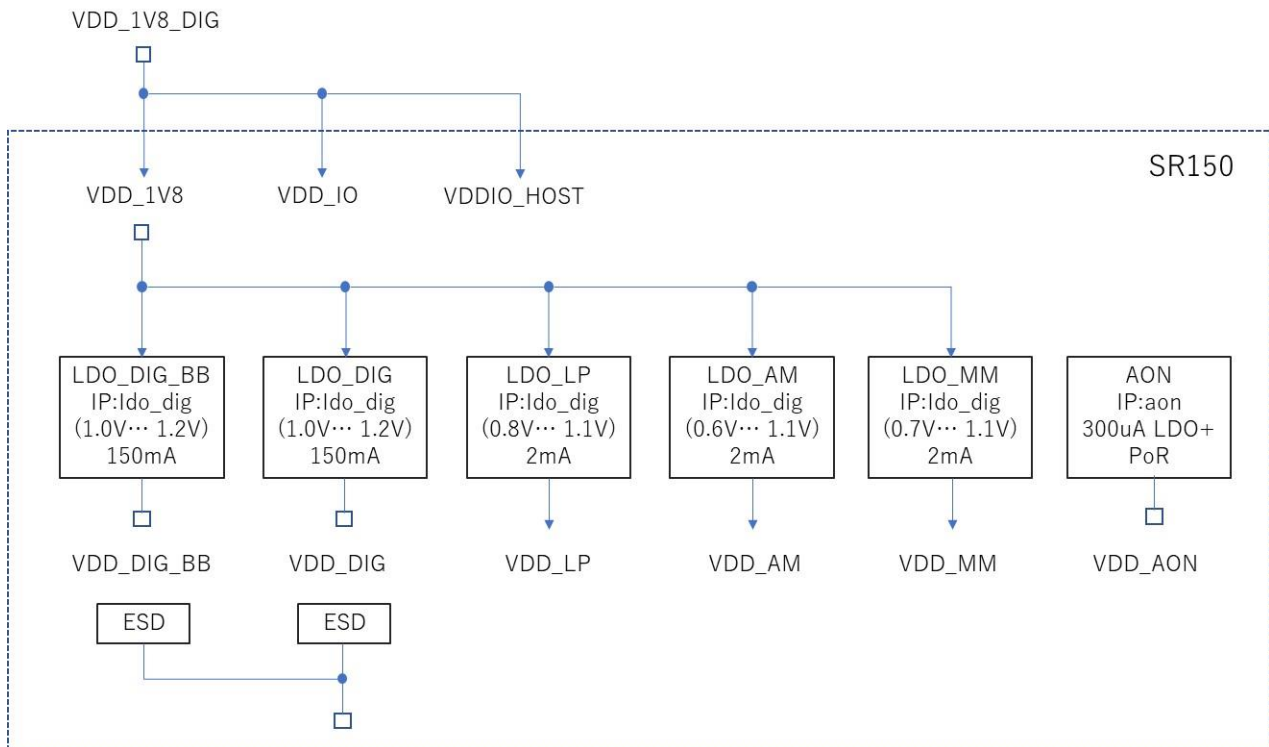

10.5. Power Timing diagrams

PMU of SR150 subsystem has a main power up sequence that require VDD_1V8_DIG, VDD_1V8_RF and CE(CHIPENALBE) to be orderly powered to boot-up.

In all cases, host communication with SR150 will only be possible after one defined amount of time from the different supply sequence setup and CE at rising edge.

High level boot sequence is indicated below, power supply start-up time should be followed. CE pin must be set to high only when VDD_IO and VDDIO_HOST are high. Then the CE pin level will be take into account from autoload phase.

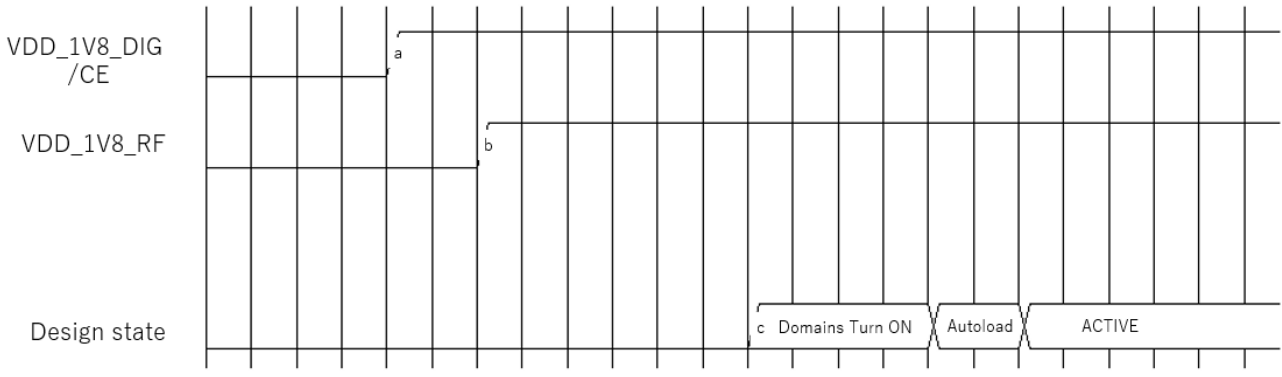

a~b : $\geq 0\mu s$
b~c : $\geq 900\mu s$

CE pin must be set to high only VDD_1V8_DIG is high.

10.5.1 Deep Power-down (DPD) sequence

In DPD Low power mode, CE need to be High all the time, Modem domain needs to be turned OFF before decided to go to DPD. All IOs are retained to same state before going to DPD. All high frequency clocks



10.5.2 Hard Power-down (HPD) sequence

HPD is lowest Power mode where only SR150 AON domain is ON and rest of the power domains of SR150s are in OFF state. (Note : note the VDD_1V8_RF supplies connected to internal RF switch and it also causing leak current. The dominant current consumption factors in HPD mode are current consumption of SR150 HPD state and leakage current of RF switch). HPD state can be entered or exited only by CE pin.

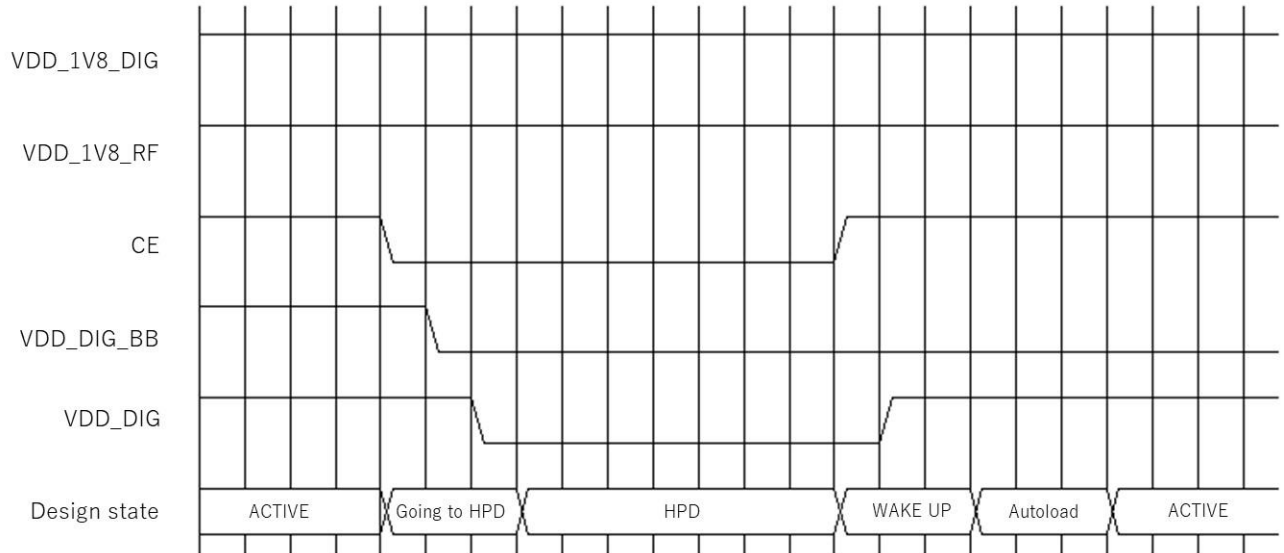

11 Host Interface (SPI)

The SR150 supports SPI-bus Master/Slave interface, up to 16.66Mbits/s.

SPI-bus configuration options

The operation mode of the SPI-bus is shown in below table, CPHA refers to the Clock Phase option and CPOL refers to the Clock Polarity. Default setting of CHPA/CPOL settings are CHPA=0, CPOL=0.

Connection
CPHA switch: Clock Phase: defines the sampling edge of MOSI data <ul style="list-style-type: none"> • CPHA = 1: data are sampled on MOSI on the even clock edges of SCK after NSS goes low • CPHA = 0: data are sampled on MOSI on the odd clock edges of SCK after NSS goes low
CPOL switch : Clock Polarity <ul style="list-style-type: none"> • CPOL = 0: the clock is idle low and the first valid edge of SCK will be a rising one • CPOL = 1: the clock is idle high and the first valid edge of SCK will be a falling one

The SPI-bus interface shares the pins with the other host interfaces that are supported by SR150. When SPI-bus is configured the functionality of the interface pins is as described in below table.

Pin name	Functionality
Host_1	SCK (Serial input Clock)
Host_2	NSS (Not Slave Select)
Host_3	MOSI (Master Out Slave In)
Host_4	MISO (Master In Slave Out)

SPI-bus functional description

When a master device transmits data to the SR150 via the MOSI line, the SR150 responds by sending data to the master device via the MISO line. This implies full-duplex transmission with both, data out and data in synchronized with the same clock signal.

SR150 starts sampling when receiving a logic low at pins NSS Host_2 pin and the clock at input pin SHOST_1. Thus, SR150 is synchronized with the master. Data from the master is received serially at the slave MOSI line and loaded in the 8-bit shift register. After the 8bit shift register is loaded, its data is transferred to the read buffer. During a write cycle, data is written into the shift register, then the SR150 waits for a clock train from the master to shift the data out on the MISO line.

Both master and slave devices must operate with the same timing. The master device always places data on the MOSI line a half cycle before the clock edge SCK, for the slave device to latch the data.

SR150 SPI data frame

CPHA=0

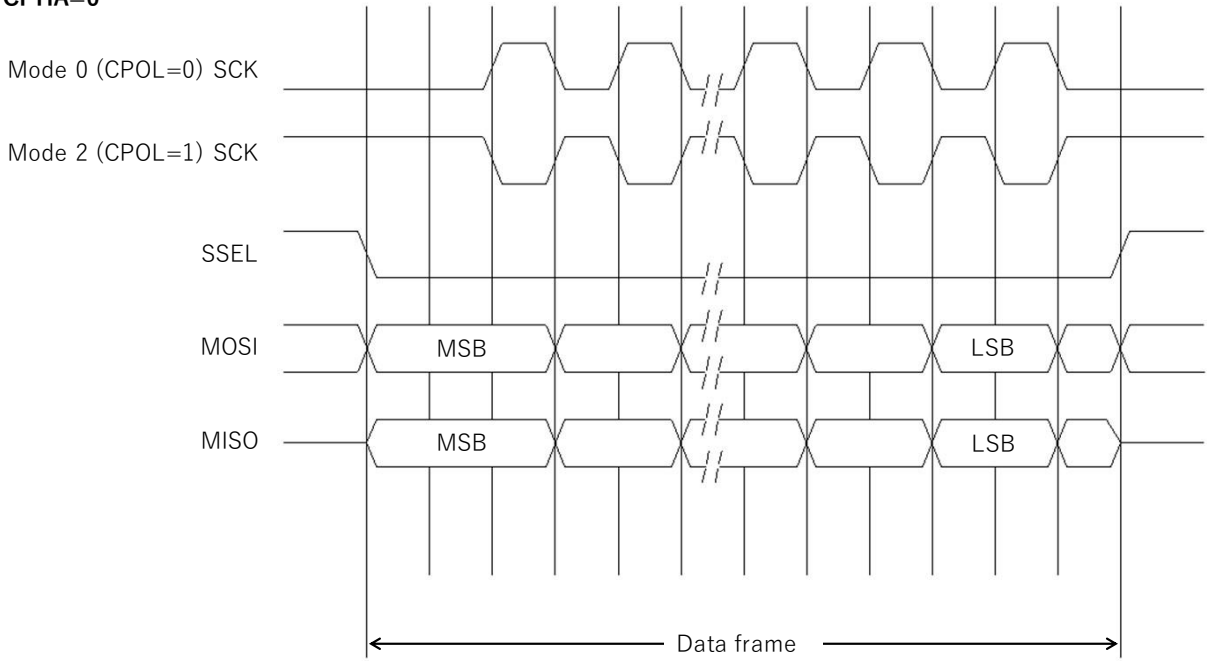

CPHA=1

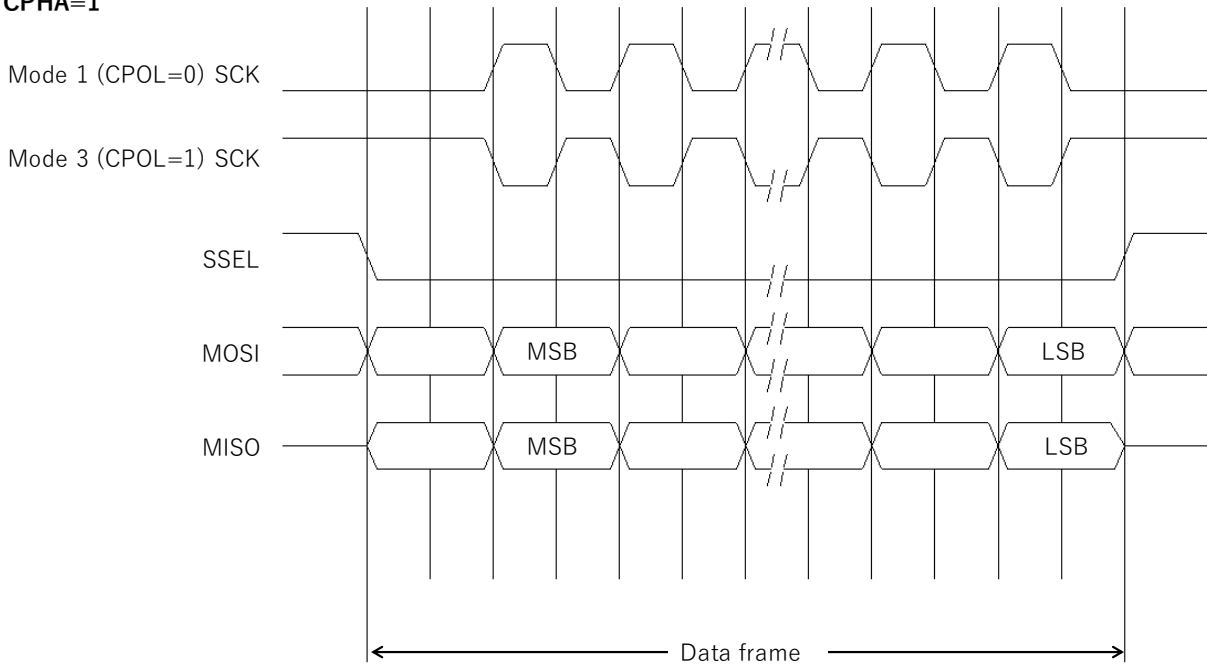

12 DC / RF Characteristics

Conditions : 25deg. C, VDD_1V8_DIG=1.8V, VDD_1V8_RF=1.8V, calibrated value in the OTP applied.

12.1 Current consumption

Items	Min.	Typ.	Max.	Unit
Hard Power Down State (HPD)		24	80	uA
DPD State retention mode		50		uA
Active State, CPU idle		15		mA
Active State, signed and encrypted FW download		18		mA
Active State, UWB time base maintenance and frame processing during active ranging		55		mA
Peak current TX/RX				
TX @ -41.3dBm/MHz		160	240	mA
Dual Rx		315	390	mA

12.2 Reference data

These specs are defined at the module pin out.

Items	Conditions	Min.	Typ.	Max.	Unit
Frequency Range	Ch5, Ch9 support	6.24	-	8.24	GHz
Data Rate	Supported data rate	6.81	6.81	31.2	Mbps
Output power ^(*)	Power density	-47	-	-41.3	dBm/MHz
Rated Output power (peak)	Power density		-	0	dBm/50Mhz
Pulse Repetition Rate			62.4		MHz
			124.8		MHz
			249.6		MHz
Rx Sensitivity	6.81Mbps		-92	-85	dBm
	27.24Mbps		-88	-80	dBm
	31.2Mbps		-88	-80	dBm
Max Input Level	CW signal or other UWB, no damage			7	dBm
Carrier Frequency Offset ^(*)		-15		15	ppm

(*1 : spec when using calibration value in the OTP)

12.3 Calibration value in OTP

There is OTP (One time programable ROM) in the SR150, and calibration value is stored in the OTP. Calibration performed in the Murata factory to all of product individually, calibration reference point defined at the module pin.

Three calibration value stored in the OTP as below.

Item	Length
TX_POWER for channel 5	4 bytes
TX_POWER for channel 9	4 bytes
RF_XTAL_CAP (Common for all channels)	3 bytes

These calibration value need to be applied after boot up or wake up from HPD. Please refer to application note to apply these values.

Application note : MCM-21F-0147_Type2BP-Applying_Calibration_Values

14 Reference Circuit

R35: "no mount" for Smaller current consumption in DPD mode.

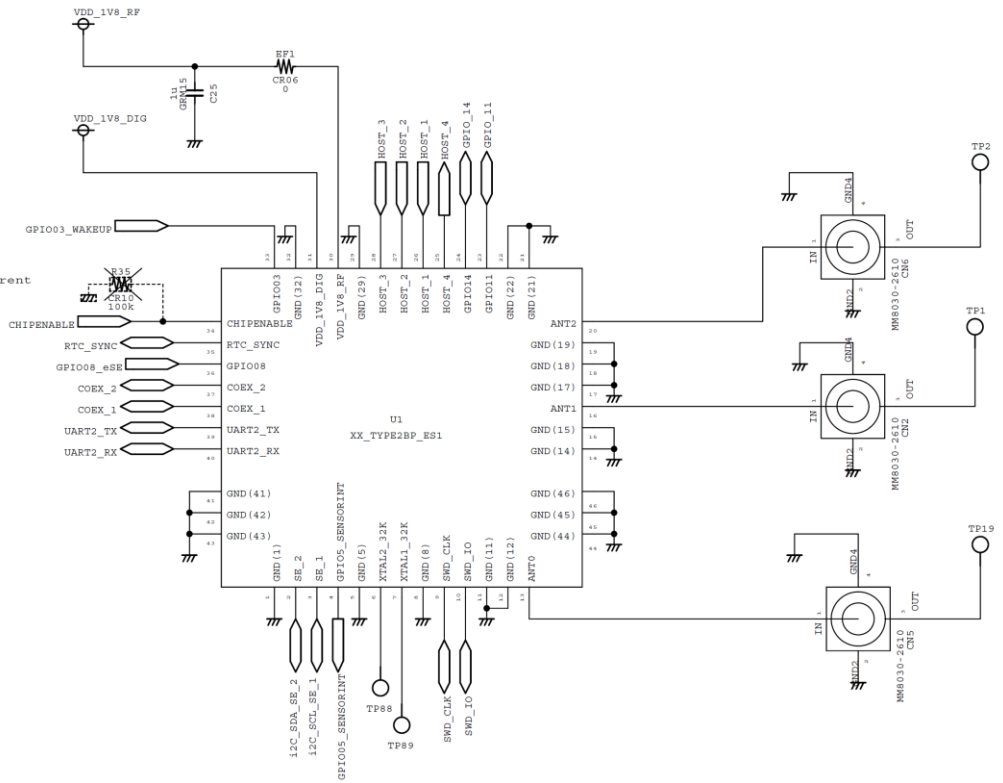

15 Tape and Reel Packing

(1) Dimensions of Tape (Plastic tape)

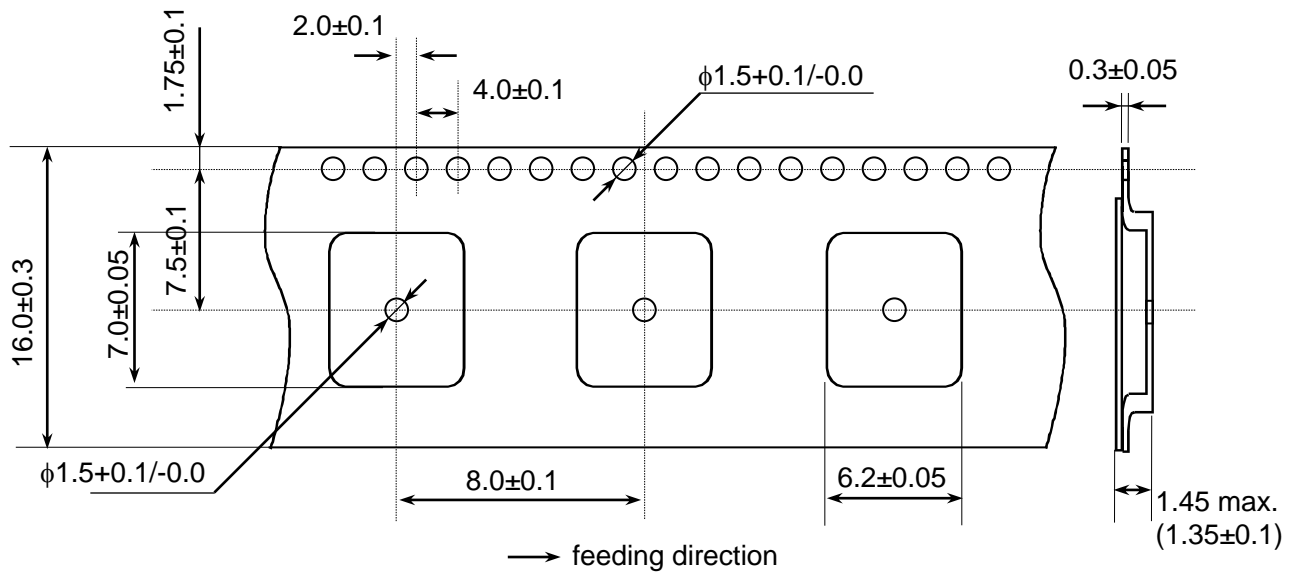

- 1) The corner and ridge radiuses (R) of inside cavity are 0.3mm max.
- 2) Cumulative tolerance of 10 pitches of the sprocket hole is ± 0.15 mm
- 3) Measuring of cavity positioning is based on cavity center in accordance with JIS/IES standard.

(Unit : mm)

(2) Dimensions of Reel

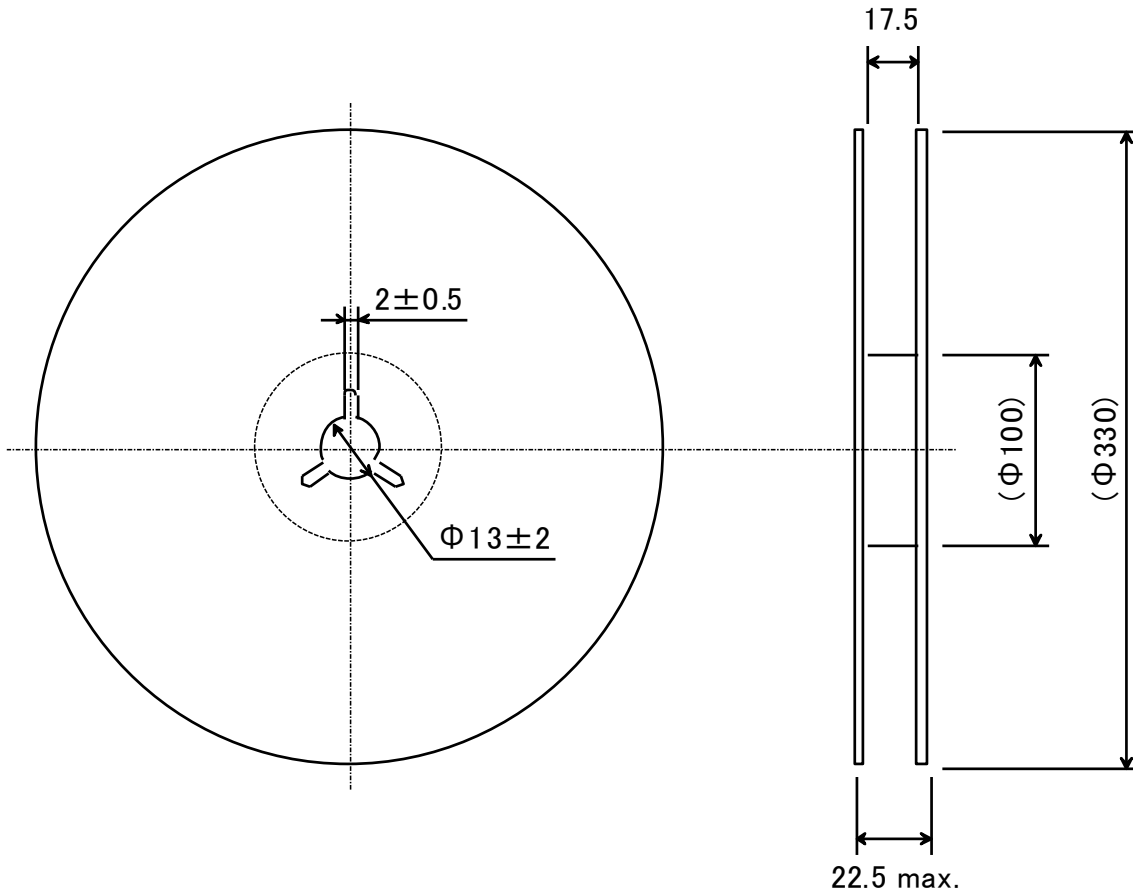

(unit : mm)

(3) Taping Diagrams

- [1] Feeding Hole : As specified in (1)
- [2] Hole for chip : As specified in (1)
- [3] Cover tape : 62 μ m in thickness
- [4] Base tape : As specified in (1)

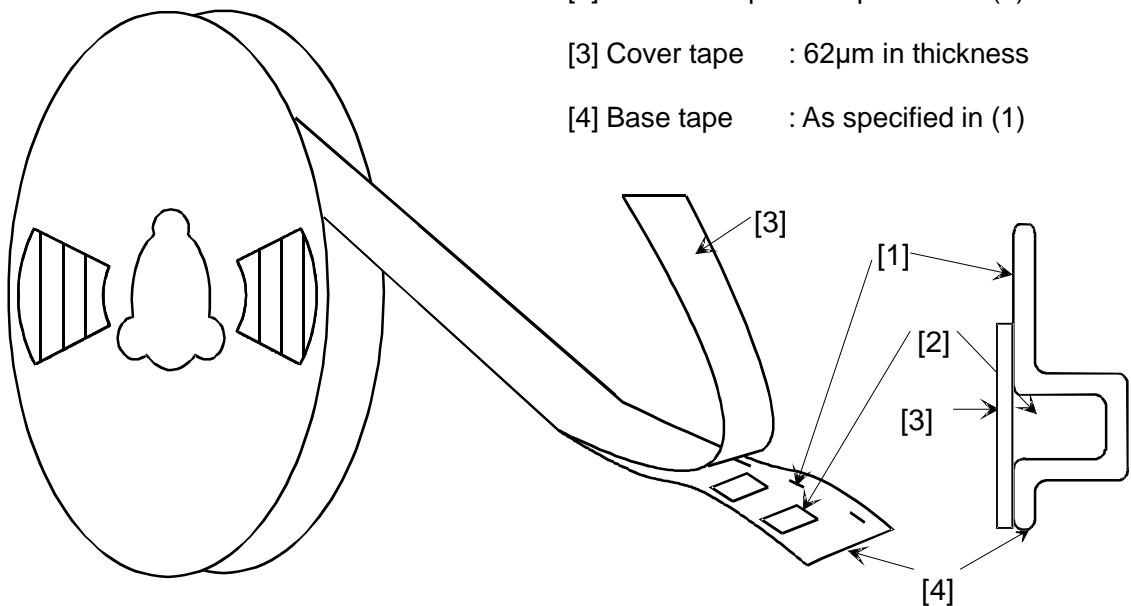

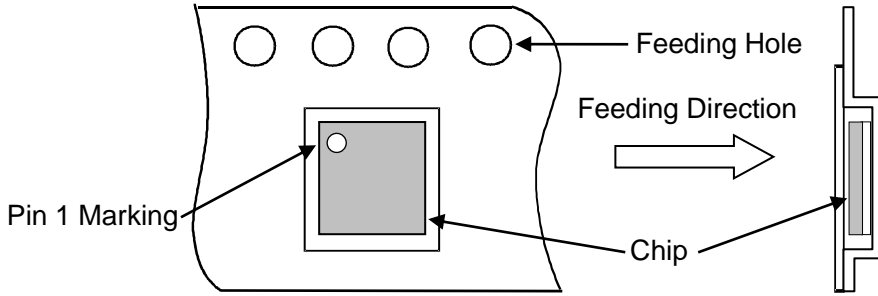

(4) Leader and Tail tape

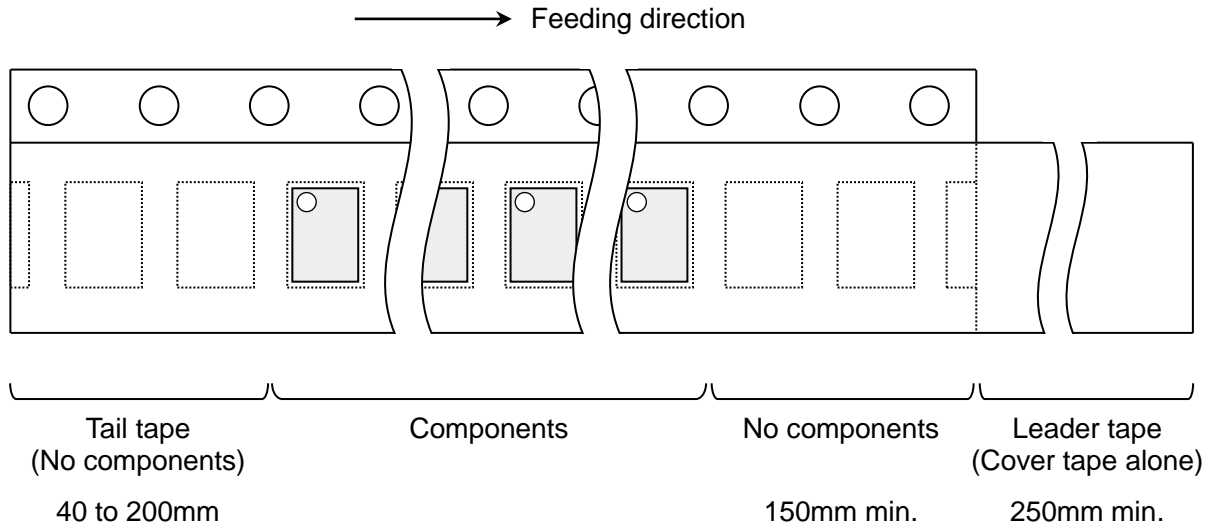

(5) The tape for chips are wound clockwise, the feeding holes to the right side as the tape is pulled toward the user.

(6) The cover tape and base tape are not adhered at no components area for 250mm min.

(7) Tear off strength against pulling of cover tape : 5N min.

(8) Packaging unit : 1000pcs./ reel

(9) material : Base tape : Plastic
Real : Plastic
Cover tape, cavity tape and reel are made the anti-static processing.

(10) Peeling of force : 1.1N max. in the direction of peeling as shown below.

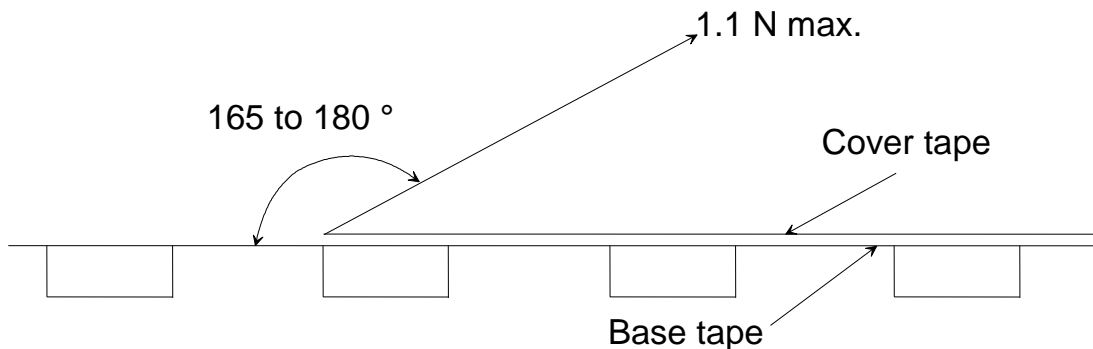

(11) Packaging (Humidity proof Packing)

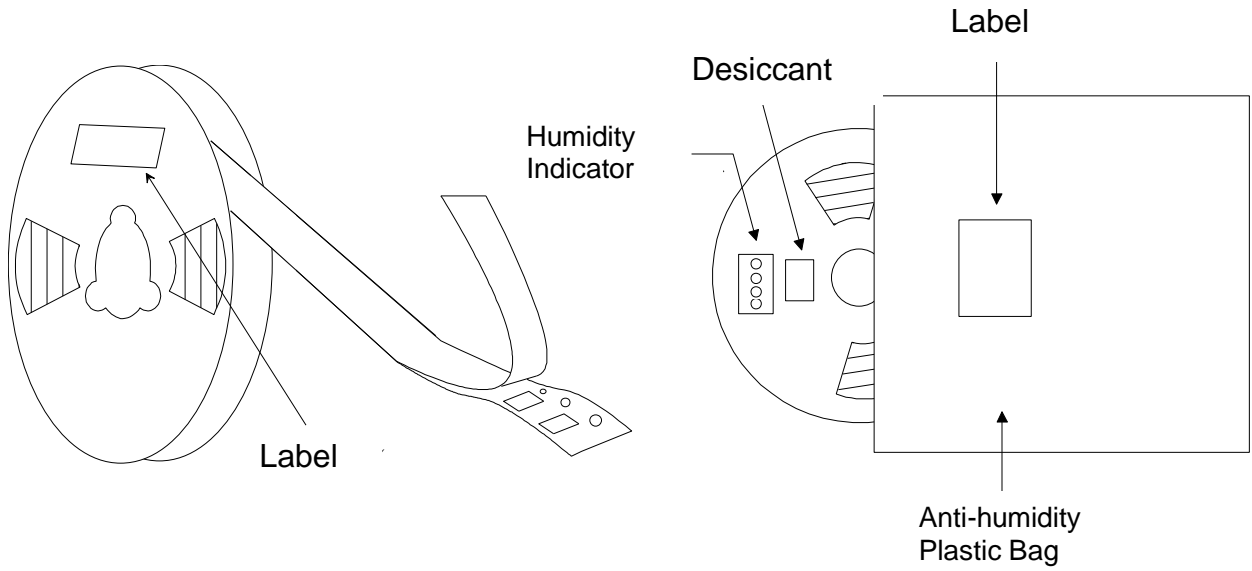

Tape and reel must be sealed with the anti-humidity plastic bag. The bag contains the desiccant and the humidity indicator.

16 **NOTICE**

16.1 **Storage Conditions:**

Please use this product within 6month after receipt.

- The product shall be stored without opening the packing under the ambient temperature from 5 to 35 °C and humidity from 20 ~ 70 %RH.
(Packing materials, in particular, may be deformed at the temperature over 40 °C)
- The product left more than 6months after reception, it needs to be confirmed the solderbility before used.
- The product shall be stored in non corrosive gas (Cl₂, NH₃, SO₂, Nox, etc.).
- Any excess mechanical shock including, but not limited to, sticking the packing materials by sharp object and dropping the product, shall not be applied in order not to damage the packing materials.

This product is applicable to MSL3 (Based on IPC/JEDEC J-STD-020)

- After the packing opened, the product shall be stored at <30 °C / <60 %RH and the product shall be used within 168 hours.
- When the color of the indicator in the packing changed, the product shall be baked before soldering.

Baking condition : 125 +5/-0 °C, 24 hours, 1 time

The products shall be baked on the heat-resistant tray because the material (Base Tape, Reel Tape and Cover Tape) are not heat-resistant.

16.2 **Handling Conditions:**

Be careful in handling or transporting products because excessive stress or mechanical shock may break products.

Handle with care if products may have cracks or damages on their terminals, the characteristics of products may change. Do not touch products with bare hands that may result in poor solder ability and destroy by static electrical charge.

16.3 **Standard PCB Design (Land Pattern and Dimensions):**

All the ground terminals should be connected to the ground patterns. Furthermore, the ground pattern should be provided between IN and OUT terminals. Please refer to the specifications for the standard land dimensions.

The recommended land pattern and dimensions is as Murata's standard. The characteristics of products may vary depending on the pattern drawing method, grounding method, land dimensions, land forming method of the NC terminals and the PCB material and thickness. Therefore, be sure to verify the characteristics in the actual set. When using non-standard lands, contact Murata beforehand.

16.4 **Notice for Chip Placer:**

When placing products on the PCB, products may be stressed and broken by uneven forces from a worn-out chucking locating claw or a suction nozzle. To prevent products from damages, be sure to follow the specifications for the maintenance of the chip placer being used. For the positioning of products on the PCB, be aware that mechanical chucking may damage products.

16.5 Soldering Conditions:

The recommendation conditions of soldering are as in the following figure.

Soldering must be carried out by the above mentioned conditions to prevent products from damage. Set up the highest temperature of reflow within 260 °C. Contact Murata before use if concerning other soldering conditions.

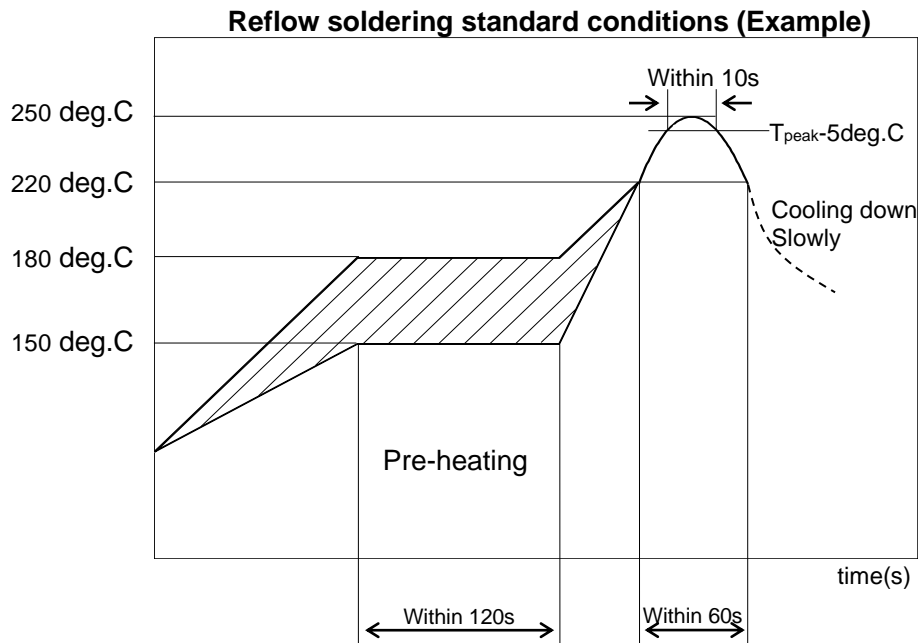

Please use the reflow within 2 times.

Use rosin type flux or weakly active flux with a chlorine content of 0.2 wt % or less.

16.6 Cleaning:

Since this Product is Moisture Sensitive, any cleaning is not recommended. If any cleaning process is done the customer is responsible for any issues or failures caused by the cleaning process.

16.7 Operational Environment Conditions:

Products are designed to work for electronic products under normal environmental conditions (ambient temperature, humidity and pressure). Therefore, products have no problems to be used under the similar conditions to the above-mentioned. However, if products are used under the following circumstances, it may damage products and leakage of electricity and abnormal temperature may occur.

- In an atmosphere containing corrosive gas (Cl₂, NH₃, SO_x, NO_x etc.).
- In an atmosphere containing combustible and volatile gases.
- Dusty place.
- Direct sunlight place.
- Water splashing place.
- Humid place where water condenses.
- Freezing place.

If there are possibilities for products to be used under the preceding clause, consult with Murata before actual use.

As it might be a cause of degradation or destruction to apply static electricity to products, do not apply static electricity or excessive voltage while assembling and measuring.

17 PRECONDITION TO USE OUR PRODUCTS

PLEASE READ THIS NOTICE BEFORE USING OUR PRODUCTS.

Please make sure that your product has been evaluated and confirmed from the aspect of the fitness for the specifications of our product when our product is mounted to your product.

All the items and parameters in this product specification/datasheet/catalog have been prescribed on the premise that our product is used for the purpose, under the condition and in the environment specified in this specification. You are requested not to use our product deviating from the condition and the environment specified in this specification.

Please note that the only warranty that we provide regarding the products is its conformance to the specifications provided herein. Accordingly, we shall not be responsible for any defects in products or equipment incorporating such products, which are caused under the conditions other than those specified in this specification.

WE HEREBY DISCLAIMS ALL OTHER WARRANTIES REGARDING THE PRODUCTS, EXPRESS OR IMPLIED, INCLUDING WITHOUT LIMITATION ANY WARRANTY OF FITNESS FOR A PARTICULAR PURPOSE, THAT THEY ARE DEFECT-FREE, OR AGAINST INFRINGEMENT OF INTELLECTUAL PROPERTY RIGHTS.

You agree that you will use any and all software or program code (including but not limited to firmware and calibration parameters) we may provide or to be embedded into our product ("Software") provided that you use the Software bundled with our product. YOU AGREE THAT THE SOFTWARE SHALL BE PROVIDED TO YOU "AS-IS" BASIS, MURATA MAKES NO REPRESENTATIONS OR WARRANTIES THAT THE SOFTWARE IS ERROR-FREE OR WILL OPERATE WITHOUT INTERRUPTION. AND MORE, MURATA MAKES NO REPRESENTATIONS OR WARRANTIES OF ANY KIND WHETHER EXPRESS OR IMPLIED WITH RESPECT TO THE SOFTWARE. MURATA EXPRESSLY DISCLAIM ANY AND ALL WARRANTIES OR CONDITIONS OF MERCHANTABILITY, FITNESS FOR A PARTICULAR PURPOSE NOR THE WARRANTY OF TITLE OR NON-INFRINGEMENT OF INTELLECTUAL PROPERTY RIGHTS.

You shall indemnify and hold harmless us, our affiliates and our licensor from and against any and all claims, costs, expenses and liabilities (including attorney's fees), which arise in connection with the using the Software.

The product shall not be used in any application listed below which requires especially high reliability for the prevention of such defect as may directly cause damage to the third party's life, body or property. You acknowledge and agree that, if you use our products in such applications, we will not be responsible for any failure to meet such requirements. Furthermore, YOU AGREE TO INDEMNIFY AND DEFEND US AND OUR AFFILIATES AGAINST ALL CLAIMS, DAMAGES, COSTS, AND EXPENSES THAT MAY BE INCURRED, INCLUDING WITHOUT LIMITATION, ATTORNEY FEES AND COSTS, DUE TO THE USE OF OUR PRODUCTS AND THE SOFTWARE IN SUCH APPLICATIONS.

- Aircraft equipment.
- Aerospace equipment
- Undersea equipment.
- Power plant control equipment
- Medical equipment.
- Traffic signal equipment.
- Burning / explosion control equipment
- Disaster prevention / crime prevention equipment.
- Transportation equipment (vehicles, trains, ships, elevator, etc.).
- Application of similar complexity and/ or reliability requirements to the applications listed in the above.

We expressly prohibit you from analyzing, breaking, reverse-engineering, remodeling altering, and reproducing our product. Our product cannot be used for the product which is prohibited from being manufactured, used, and sold by the regulations and laws in the world.

We do not warrant or represent that any license, either express or implied, is granted under any our patent right, copyright, mask work right, or our other intellectual property right relating to any combination, machine, or process in which our products or services are used. Information provided by us regarding third-party products or services does not constitute a license from us to use such products or services or a warranty or endorsement thereof. Use of such information may require a license from a third party under the patents or other intellectual property of the third party, or a license from us under our patents or other intellectual property.

Please do not use our products, our technical information and other data provided by us for the purpose of developing of mass-destruction weapons and the purpose of military use.

Moreover, you must comply with "foreign exchange and foreign trade law", the "U.S. export administration regulations", etc.

Please note that we may discontinue the manufacture of our products, due to reasons such as end of supply of materials and/or components from our suppliers.

By signing on specification sheet or approval sheet, you acknowledge that you are the legal representative for your company and that you understand and accept the validity of the contents herein. When you are not able to return the signed version of specification sheet or approval sheet within 30 days from receiving date of specification sheet or approval sheet, it shall be deemed to be your consent on the content of specification sheet or approval sheet. Customer acknowledges that engineering samples may deviate from specifications and may contain defects due to their development status. We reject any liability or product warranty for engineering samples. In particular we disclaim liability for damages caused by

- the use of the engineering sample other than for evaluation purposes, particularly the installation or integration in the product to be sold by you,
- deviation or lapse in function of engineering sample,
- improper use of engineering samples.

We disclaim any liability for consequential and incidental damages.

If you can't agree the above contents, you should inquire our sales.

APPENDIX

Radio Regulatory certification by country for LBUA0VG2BP
<FCC>

FCC ID: VPYLB2BP

Since this module is not sold to general end users directly, there is no user manual of module.
For the details about this module, please refer to the specification sheet of module.
This module should be installed in the host device according to the interface specification (installation procedure).

●Warning;

CFR §15.521(a) notice
This module may not be employed for the operation of toys. Operation onboard aircraft, ship or satellite is prohibited.
CFR §15.519 a(2) notice
The use of antennas mounted on outdoor structures, e.g., antennas mounted on the outside of a building or on a telephone pole, or any fixed outdoors infrastructure is prohibited. Antennas may be mounted only on the handheld UWB device.

This device complies with part 15 of the FCC Rules. Operation is subject to the following two conditions: (1) This device may not cause harmful interference, and (2) this device must accept any interference received, including interference that may cause undesired operation.

This device complies with below part 15 of FCC Rules.
Part 15 Subpart F

The modular transmitter is only FCC authorized for the specific rule parts (i.e., FCC transmitter rules) listed on the grant, and the host product manufacturer is responsible for compliance to any other FCC rules that apply to the host not covered by the modular transmitter grant of certification.
The final host product still requires Part 15 Subpart B compliance testing with the modular transmitter installed.

The OEM integrator is responsible for ensuring that the end-user has no manual instruction to remove or install module, this module has been evaluated stand alone to meet portable use without restriction, however, if a host product also contains other transmitter(s) and antenna(s), necessary test or evaluation needs to be performed in order to meet the requirement.
Antenna Change Notice to Host manufacturer
If you desire to increase antenna gain and either change antenna type or use same antenna type certified, a Class II permissive change application is required to be filed by us, or you (host manufacturer) can take responsibility through the change in FCC ID(new application) procedure followed by a Class II permissive change application.

This module needs to supply a regulated voltage from host device.

- VDD_1V8_DIG: 1.71~1.98V
- VDD_1V8_RF: 1.71~1.98V

Since there is no space which indicates FCC ID on this module, FCC ID is indicated in a manual.
If the FCC ID is not visible when the module is installed inside another device,
then the module is installed must also display a label referring to the enclosed module.

The OEM integrator has to be aware not to provide information to the end user regarding how to install or remove this RF module in the end user's manual of the end product which integrates this module.
The end user manual shall include all required regulatory information/warning as shown in User manual.

- The following statements must be described on the user manual of the host device of this module;

Contains Transmitter Module FCC ID: VPYLB2BP or Contains FCC ID: VPYLB2BP

T This device complies with part 15 of the FCC Rules. Operation is subject to the following two conditions: (1) This device may not cause harmful interference, and (2) this device must accept any interference received, including interference that may cause undesired operation.

*If it is difficult to describe this statement on the host product due to the size, please describe in the User's manual.

FCC CAUTION

Changes or modifications not expressly approved by the party responsible for compliance could void the user's authority to operate the equipment.

<ISED>

Model Name: LBUA0VG2BP

IC Number: 772C-LB2BP

Since this module is not sold to general end users directly, there is no user manual of module. For the details about this module, please refer to the specification sheet of module. This module should be installed in the host device according to the interface specification (installation procedure).

- The following information must be indicated on the host device of this module.

Contains IC: 772C-LB2BP

- The following statements must be described on the user manual of the host device of this module;

This device complies with Industry Canada's applicable licence-exempt RSSs. Operation is subject to the following two conditions:

- (1) This device may not cause interference; and
- (2) This device must accept any interference, including interference that may cause undesired operation of the device.

Le présent appareil est conforme aux CNR d'Industrie Canada applicables aux appareils radio exempts de licence. L'exploitation est autorisée aux deux conditions suivantes :

- 1) l'appareil ne doit pas produire de brouillage;
- 2) l'utilisateur de l'appareil doit accepter tout brouillage radioélectrique subi, même si le brouillage est susceptible d'en compromettre le fonctionnement.

*If it is difficult to describe this statement on the host product due to the size, please describe in the User's manual.

- Warning;

CFR §15.521(a) notice

This module may not be employed for the operation of toys. Operation onboard aircraft, ship or satellite is prohibited.

CFR §15.519 a(2) notice

The use of antennas mounted on outdoor structures, e.g., antennas mounted on the outside of a building or on a telephone pole, or any fixed outdoors infrastructure is prohibited. Antennas may be mounted only on the handheld UWB device.

If the antenna of the end product is removed, please describe the follow warning on the manual of the end product which contains this module.

This radio transmitter (IC Number: 772C-LB2BP) identify the device by certification number or model number if Category II) has been approved by Industry Canada to operate with the antenna types listed below with the maximum permissible gain indicated. Antenna types not included in this list, having a gain greater than the maximum gain indicated for that type, are strictly prohibited for use with this device.

*Ch.5 : MTD-ANT-027-1-A_UWB_ANT18mm Patch antenna Gain: +0.9 dBi

*Ch.9 : MTD-ANT-027-1-A_UWB_ANT18mm Patch antenna Gain: +2.7 dBi

Le présent émetteur radio (IC Number : 772C-LB2BP) a été approuvé par Industrie Canada pour fonctionner avec les types d'antenne énumérés ci-dessous et ayant un gain admissible maximal. Les types d'antenne non inclus dans cette liste, et dont le gain est supérieur au gain maximal indiqué, sont strictement interdits pour l'exploitation de l'émetteur.

Type d'antenne

*Ch.5 : MTD-ANT-027-1-A_UWB_ANT18mm Patch antenna Gain: +0.9 dBi

*Ch.9 : MTD-ANT-027-1-A_UWB_ANT18mm Patch antenna Gain: +2.7 dBi

- The following statements must be described on the user manual of the host device of this module;

Data transmission is always initiated by software, which is then passed down through the MAC, through the digital and analog baseband, and finally to the RF chip. Several special packets are initiated by the MAC. These are the only ways the digital baseband portion will turn on the RF transmitter, which it then turns off at the end of the packet. Therefore, the transmitter will be on only while one of the aforementioned packets is being transmitted. In other words, this device automatically discontinues transmission in case of either absence of information to transmit or operational failure.

La transmission des données est toujours initiée par le logiciel, puis les données sont transmises par l'intermédiaire du MAC, par la bande de base numérique et analogique et, enfin, à la puce RF. Plusieurs paquets spéciaux sont initiés par le MAC. Ce sont les seuls moyens pour qu'une partie de la bande de base numérique active l'émetteur RF, puis désactive celui-ci à la fin du paquet. En conséquence, l'émetteur reste uniquement activé lors de la transmission d'un des paquets susmentionnés. En d'autres termes, ce dispositif interrompt automatiquement toute transmission en cas d'absence d'information à transmettre ou de défaillance.

*If it is difficult to describe this statement on the host product due to the size, please describe in the User's manual.

●RF Power

Modulation	Channel	MAXIMUM TUNE UP TOLERANCE	
		Peak Power	Average Power
BPM-BPSK	5, 9	0dBm/50MHz	-41.3dBm/MHz
BPSK	5, 9	0dBm/50MHz	-41.3dBm/MHz

●Antenna

■Certified Antenna information

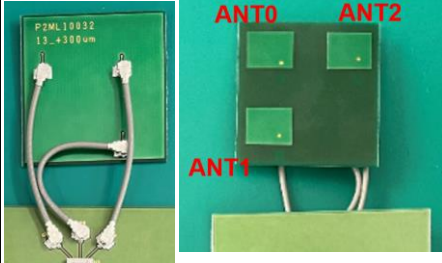
Maker	Supported Antenna				Appearance
	P/N	Type	Gain [dBi]		
			5ch	9ch	
Murata	MTD-ANT-027-1-A_UWB_ANT18mm	Patch	0.9	2.7	

■Please perform the antenna design that followed the specifications of the antenna.

■50-ohm line(microstrip line pattern)

Certification tests are conducted in the following patterns.

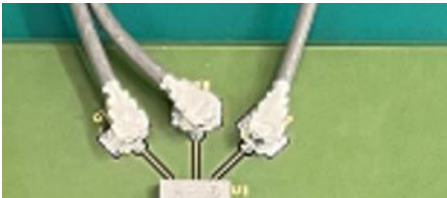

The 50ohm microstrip line needs to be copied when module is installed in the End product.

Murata provides set makers with Gerber data or something similar

<Japan>

Classification of Specified Radio Equipment: Article 2 paragraph1 item (47)-3
Application Model Name: LBUA0VG2BP
Certification Number: 003-220111

This module has received "CERTIFICATION for TYPE CERTIFICATION" under the Japanese Radio Law.

It is recommended that the indication of (1) or (2) below is described on the product incorporating this module **in Japanese**. If there is any problem with the indication of (1) or (2) on the product, we recommend indicating (1) or (2) in the user manual or on the package of the product incorporating this module, or electronic display on the product. In the case of the electronic display, it is necessary to describe "using the electronic display" + "how to reach to below indication" in the user manual of the product.

(1)

本製品は、電波法に基づく工事設計認証(認証番号:003-220111)を受けた特定無線設備を内蔵しています。

(2)

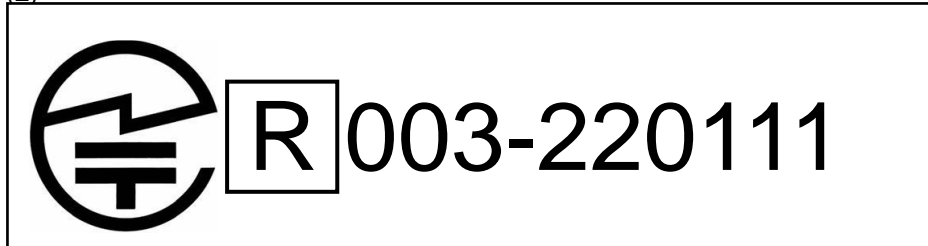

(English Translation)

(1)

This product incorporates specified radio equipment that has received CERTIFICATION for TYPE CERTIFICATION (certification number: 003-220111) based on the Japan Radio Act.