



Long-Term Support
World Class Quality

8Mb High Speed with ECC Async SRAM 32Mb High Speed Async SRAM

8Mb High Speed Low Power Asynchronous SRAM with Error Correction Code (ECC)

ISSI's latest Error Correction based 8Mb High Speed Low Power Asynchronous SRAM is in production. This innovative design reinforces ISSI's long-term commitment to SRAMs with the highest quality and performance. This industry's first Error Correction Code (ECC) based Asynchronous SRAM meets high quality requirements in automotive, industrial, military-aerospace, and other applications.

Error Detection and Error Correction

- Independent ECC with hamming code for each byte
- Detect and correct one bit error per each byte
- Better reliability than parity code schemes which can only detect an error but not correct an error
- Backward Compatible: Drop in replacement to current in industry standard devices (without ECC)

Applications: Automotive, Industrial/Medical, Telecom/Networking

Additional ECC Async SRAMs: 1Mb, 2Mb, 4Mb, 16Mb

Key Features

| | IS61WV51216EDBLL (I) | IS64WV51216EDBLL (A3) | Comments |
|------------------------|------------------------------------|------------------------------------|---|
| Temperature Support | Industrial [-40°C to +85°C] | Automotive [-40°C to +125°C] | |
| Technology | 65nm | 65nm | |
| Standby Current | 15mA | 35mA | Typical value 2mA |
| Operating Current | 50mA | 65mA | Typical value 15mA |
| Data Retention Current | 15mA | 35mA | Typical value 2mA |
| Packaging | TSOP-II [44 pins] BGA [48 pins] | TSOP-II [44 pins] BGA [48 pins] | Pin compatible w/ industry standard 8Mb Async. SRAM |
| Speed | 10ns | 10ns | |
| Copper Leadframe | Yes | Yes | Improved thermal performance |
| Lead-free and Leaded | Yes | Yes | RoHS Compliant |
| Availability | Production | Production | |

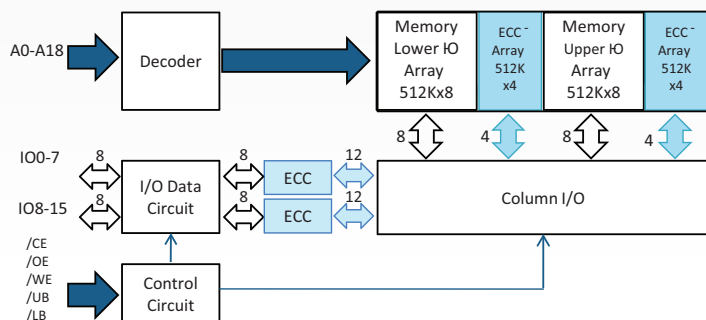

32Mb High Speed Low Power SRAM IS61/64WV204816BLL

ISSI is now sampling a 32Mb High Speed Low Power Asynchronous SRAM, the latest addition to our SRAM portfolio. This innovative design reinforces ISSI's longterm commitment to SRAMs with the highest quality and performance. 32Mb SRAM provides an access time of 10ns at Automotive, A3 temperature range [-40°C to +125°C].

Applications: Automotive, Industrial/Medical, Telecom/Networking

Key Features

| | IS61WV204816BLL (I) | IS64WV204816BLL (A3) | Comments |
|-------------------------|------------------------------------|------------------------------------|---------------------------------------|
| Temperature Support | Industrial [-40°C to +85°C] | Automotive [-40°C to +125°C] | |
| Technology | 40nm | 40nm | |
| Supply Voltage | 2.4V ~ 3.6V | 2.4V ~ 3.6V | |
| Operating Current [Max] | 95mA | 140mA | Typical value 60 mA |
| Standby Current [Typ] | 4mA | 4mA | |
| Packaging | TSOP-I [48 pins] BGA [48 balls] | TSOP-I [48 pins] BGA [48 balls] | Pin compatible w/ 16Mb Async. SRAM |
| Speed | 10ns | 12ns | |
| Copper Leadframe | Yes | Yes | |
| Lead-free PKG | Yes | Yes | RoHS Compliant |
| Availability | Sampling Now | Sampling Now | |

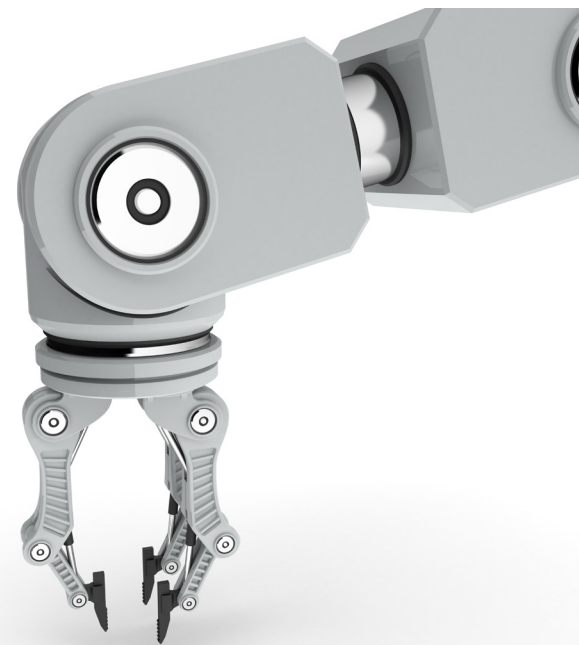



HyperRAM™ DRAM Based memory with HyperBus™ Interface

Features:

- Hidden Refresh operation
- Very Low Bus Signal Count :
 - 12 pins for 1.8V [with CK,CK#]
 - 11 pins for 3.0V [CK only]
- Max. Frequency :
 - 166MHz at VDD = 1.8V
 - 100MHz at VDD = 3.0V
- Low Power Consumption :
 - Burst Operation Current at 166MHz, 1.8V = 60mA [Max]
 - Standby Current @ 105°C, 1.8V = 300uA [Max]
 - Deep Power Down Current @ 105°C, 1.8V = 10uA [Max]

Package:

- 24-pin BGA

HyperRAM™ Pin-Outs (In evaluation):

- 24-pin [5 x 5 ball array]
- PKG Body Size : 6 mm x 8 mm
- Ball Pitch : 1.0mm

Densities:

- 64Mb [8Mb x 8] , 32Mb [4Mb x8]
- 128Mb [16Mb x8], 256Mb [32Mb x8]

Availability:

- 64Mb
 - Production Now!
- 128Mb
 - Samples Available Now!
- 32Mb, 256Mb
 - Call Factory

Automotive Temperature Grades:

- Automotive, A1 [-40°C to 85°C]
- Automotive, A2 [-40°C to 105°C]

Applications:

- Infotainment
- Advanced Driver Assistance Systems
- Smart Appliance
- Factory Automation
- Medical
- LED Projector
- D-SLR Camera
- Auto-Cluster

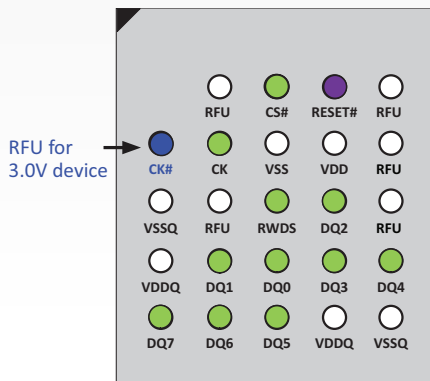

4Mbit Latched SRAM 256Kx16 High speed Asynchronous CMOS stat RAM with Latched Address & ECC

Features:

- High-speed access time: 12ns, 15ns
- Single power supply
 - 2.4V-3.6V VDD
- Ultra Low Standby Current with ZZ# pin
 - IZZ = 80uA @ 125°C
- Error Detection and Correction per individual 8-bits [byte] with optional ERR1/ERR2 output pin:
 - ERR1 pin indicates 1-bit error detection and correction.
 - ERR2 pin indicates multi-bit error detection
- ALE# pin to latch Address & CS# signals.
- Industrial and Automotive temperature support
- Lead-free available

BGA Pinout:

48-Pin mini BGA (6mm x 8mm) with ZZ# and ERR1/2

