

SmartMesh IP™ RFID Solution Board

High-Accuracy RFID Reader with Zero-Touch Mesh Network Deployment

Asset location and tracking is a key requirement in many businesses, including sectors such as retail, industrial and healthcare. The ability to locate and track assets accurately, and in real time, can be a key contributor to business performance, and in many cases a critical part of operations. Mesh networking is ideal for cost-effective, resilient and low-power asset tracking applications. The IoTechnics SmartMesh IP™ RFID Solution Board is a complete development environment for creating mesh networked RFID products for such applications.

SmartMesh IP™ has low-power requirements, is resilient to failure and require minimal configuration. This enables a more cost-effective, less resource-intensive deployment of asset location and tracking solutions. The board uses Analog Devices SmartMesh IP™ technology to create multi-hop networks that do not rely on existing infrastructure, simplifying deployment of devices and with low technical overheads. The onboard microcontroller is fully programmable using Analog Devices CrossCore® Embedded Studio enabling the creation of bespoke solutions. To further assist the development process, test applications, API and sample code are also provided.

Applications

Tracking of RFID tagged items. Examples include:

- > Inventory/stock control
- > Retail sales information tracking
- > Security / theft prevention
- > Asset tracking
- > Counterfeit protection

SmartMesh IP™ RFID Solution

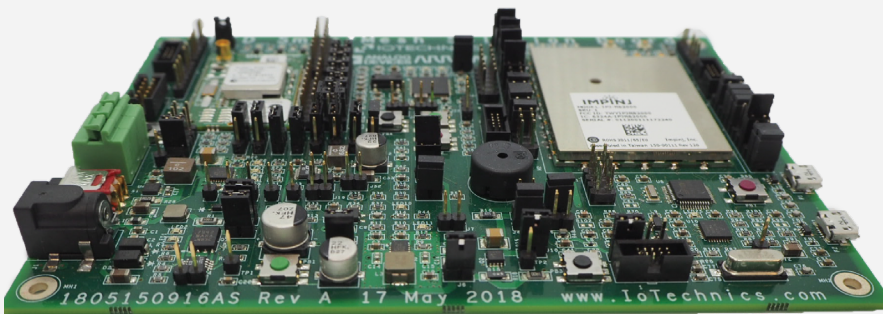

Kit Contents

- > SmartMesh IP™ RFID solution board
- > RFID antenna
- > SmartMesh antenna
- > Power supply
- > USB cable

Software and Documentation

Firmware/application source code and documentation for:

- > Inventory/stock control example
- > Security alerting example

SmartMesh IP™ RFID Solution Board Block Diagram

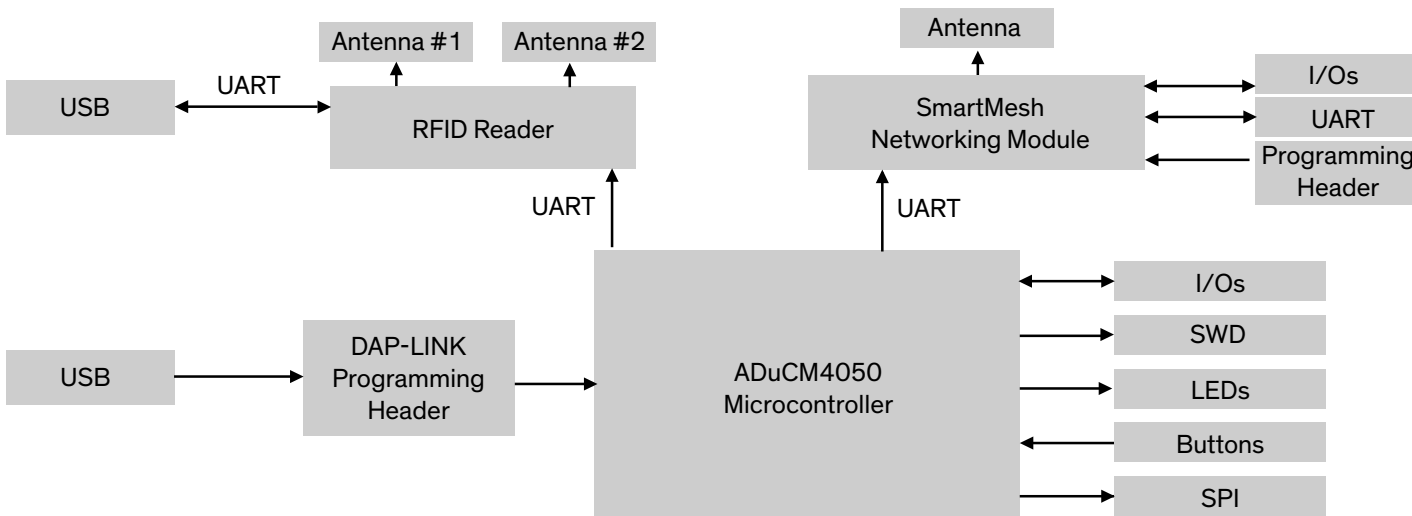

Key Features

- > High-speed RFID reader capable of reading hundreds of tags per second, with a range of up to 10m
- > Low power, zero-touch mesh networking
- > Ultra low power Arm® Cortex®-M4F processor
- > Flexible power design with battery or mains operation
- > MBED DAP-Link debug support
- > RFID and SmartMesh modules can be programmed and used in isolation
- > Example firmware/application source code and documentation for common use cases
- > Industry standard development tools: CrossCore® Embedded Studio, Keil, IAR

Key Components

- > Analog Devices ADuCM4050 MCU
- > Impinj INDY RS2000 RFID Reader
- > Analog Devices LTP5902 SmartMesh IP™ Module

Customization Services

The SmartMesh IP™ RFID Solution Board is designed for pre-production purposes and can be used for proof-of-concept development and testing. loTechnics can help create customised production-ready systems, with the following services:

- > Customised hardware/firmware to meet additional sensing needs, environmental requirements or low power requirements
- > Bespoke application development for mobile, desktop or web
- > Scalable cloud or self-hosted analytics and dashboard development
- > Help with regulatory requirements

Ordering Information

The SmartMesh IP™ RFID Solution Board can be ordered from Arrow - available Q2, 2019
Part # is SB-DUSTRFID-B Rev B

Chat live and in real time on arrow.com or connect with a Customer Support team:

North America
+1 855 326 4757

Europe, Middle East, & Africa
+44 20 3936 5486

Asia-Pacific
+86 400 920 0628



Arrow Electronics, Inc.
9201 East Dry Creek Road
Englewood, CO 80112, USA